

OWNERS  
MANUAL

*Bally*<sup>®</sup>

PROFESSIONAL ARCADE<sup>T.M.</sup>

FUN & BRAINS<sup>T.M.</sup>

# Bally<sup>®</sup>

PROFESSIONAL ARCADE  
FUN & BRAINS





## GENERAL SAFEGUARDS

1. Do not install the Bally Professional Arcade near heat sources such as radiators or air ducts, or in a place subject to direct sunlight, excessive dust, mechanical vibration or shock.
2. Allow adequate air circulation to prevent heat build up. Do not block vents.
3. Do not open the Bally Professional Arcade cabinet as it will void your warranty. There are no user servicable parts inside.
4. To disconnect the cord, pull it out by the ac adapter housing. Never pull the cord itself.
5. Save the original shipping carton and packing materials. They will come in handy if you ever have to ship your set.

## NOTE FCC PROHIBITS

1. The use of additional flat twin lead in from the TV/game switch box to your TV receiver.
2. Connecting any additional TV receivers to the TV/game switch box.
3. Connecting the Bally Professional Arcade directly to your television antenna or cable TV connector. All connections are to be made through the TV/game switch box.

Violation of these rules could cause TV interference to other TV receivers in your area.

## TABLE OF CONTENTS

|  |    |
|--|----|
| General Safeguards . . . . .                   | 1  |
| FCC Caution . . . . .                          | 1  |
| Exclusive Features . . . . .                   | 2  |
| Connection to TV Receiver . . . . .            | 3  |
| Hand Controls . . . . .                        | 6  |
| Gunfight . . . . .                             | 7  |
| Checkmate . . . . .                            | 9  |
| Scribbling . . . . .                           | 11 |
| Calculator . . . . .                           | 13 |
| With Bally/Always More Games to Come . . . . . | 15 |
| Bally Basic . . . . .                          | 16 |
| Audio Interface . . . . .                      | 17 |

BALLY MANUFACTURING CORPORATION  
CONSUMER PRODUCTS DIVISION  
10750 West Grand Avenue  
Franklin Park, Illinois 60131  
(312) 451-1360  
Cable Address: Midco • Telex No. 72-1596

## EXCLUSIVE FEATURES

Your Bally Professional Arcade is equipped with a number of exclusive features which are not found in other "Programable type" video games.

### TELEVISION TUBE PROTECTION CIRCUIT

It has been said that video games may harm your television tube if left on for excessive periods of time. This is not true of the Bally Professional Arcade. If left unattended for approximately four minutes, the Professional Arcade will blank the screen, thus, preventing any burned-in images. Pressing any key on the keypad will resume operation.

### PAUSE

To pause in the middle of a game, press the clear "C" key to blank the screen. Press the clear "C" key again to resume at the exact point at which you blanked the screen.

### REMOTE GAME SELECTION

The Bally Professional Arcade is the only programmable video game with remote game selection. All of the keypad entries required to select and initiate a game may be made using a hand control from your easy chair.

The procedure for remote game selection is easy and only three steps are involved. Let's play CHECKMATE as an example.

Turn the power switch on for the Bally Professional Arcade, a listing of the games by number should appear on your TV screen. (If it does not, press the RESET button, or refer to page 3 on system connections.)

Remote game selection works only with the #1 Player control.

1. Press the trigger. This tells the Arcade that you wish to use remote game selection. A red number will appear in the lower-left corner of the TV screen.

2. Twist the knob on the hand control to change the red number. Adjust the knob until the number of entry that you want is shown. For CHECKMATE this number would be 2.
3. Press the trigger again. This time it will register your choice with the Bally Professional Arcade.

The Professional Arcade will now ask "ENTER # OF GAMES". Press the trigger once for remote game selection. Adjust the knob to indicate the number of games you wish. Register your choice by pressing the trigger.

Now follow the same 1,2,3. sequence to enter the number of players.

When a game is over, you may select another game by pulling the trigger to get the menu. Then pull trigger, adjust knob and pull trigger again to enter your choice.

### USER—PROGRAMMABLE GAME TIME

You are not limited to a prescribed length of time or fixed scores when playing our games. With the use of the keypad, you can program most games to a score of 1 to 99 or from 1 second to 10 minutes in time.

### CHANNEL 3 OR 4 OPERATION

Sometimes, depending upon where you live, you may get interference from the channel you use for playing your video game. With the Bally Professional Arcade you can use either channel 3 or 4 of your television receiver.

### EXPANDABILITY

Someday soon you may decide that you would like to have a computer in your home that will make your life a whole lot easier. Well, you have got a good start on having one with owning a Bally Professional Arcade. With an additional purchase of some of our forthcoming accessories, you will be able to transform your Bally Professional Arcade into a very powerful home computer.

## CONNECTING BALLY PROFESSIONAL ARCADE TO YOUR TV RECEIVER

Included with your Bally Professional Arcade is a TV/game switch box. (Fig. 1) This switch box permits you to select either the Bally Professional Arcade or your regular TV viewing. Simply move the selector switch to the Mode desired.

### I. CONNECTING THE TV/GAME SWITCH BOX YOUR TV RECEIVER

(Note the back of your TV receiver).

1. If you have 300 ohm ribbon type flat lead into the VHF antenna terminals, go to 300 ohm installation.
2. If you have 75 ohm round coaxial cable into the VHF antenna jack, go to 75 ohm installation.

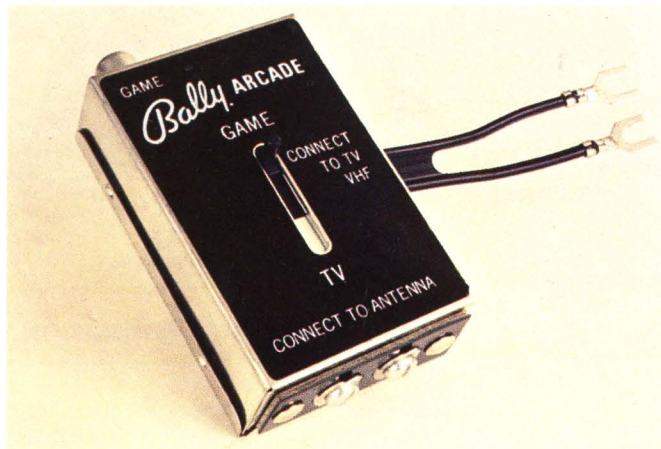

### 300 OHM INSTALLATION (fig.2)

1. Locate the VHF antenna terminals on the back of your television receiver. Remove the existing lead in wires connected to these terminals and attach them to the terminals marked "Connect to Antenna" at the base of the TV/game switch box.
2. Connect the short length of antenna wires coming from the side of the TV/game switch box to the VHF antenna terminals of your TV receiver.

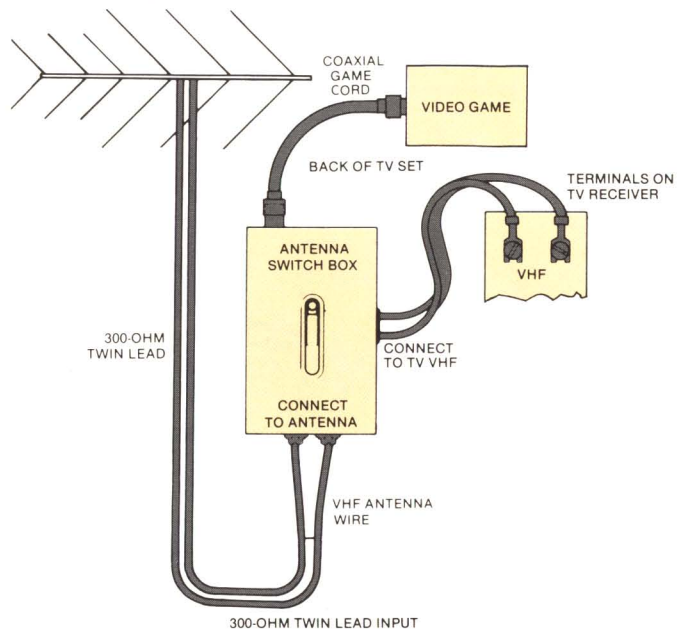



## 75 OHM INSTALLATION (fig.3)

**Note:** With this system it will be necessary to supply a 75 ohm to 300 ohm matching transformer available from your dealer or any television service center.

1. Remove the coaxial connector from the back of your TV receiver and connect it to the matching transformer.
2. Connect the 300 ohm flat twin lead (from the matching transformer) to the terminals marked "Connect To Antenna" at the base of the TV/game switch box.

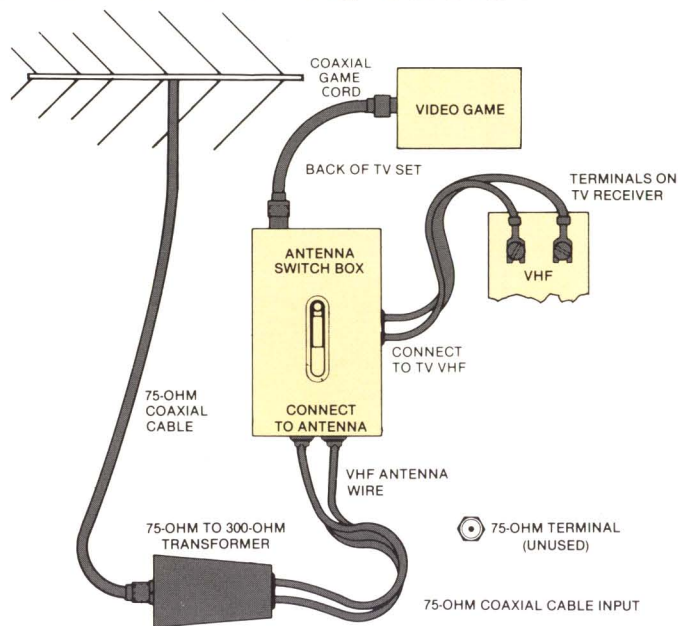

Figure 3

3. Connect the short length of the antenna wires coming from the side of the TV/game switch box to the VHF antenna terminals of your TV receiver.

**II. CAREFULLY UNROLL THE COAXIAL CABLE FROM THE ARCADE CONSOLE AND PLUG IT INTO THE TV/GAME SWITCH BOX MARKED "GAME".**

**III. PLUG THE POWER ADAPTOR INTO A 120 V AC OUTLET.**

**IV. PLUG EACH HAND CONTROL INTO ITS APPROPRIATE CONNECTOR ON REAR OF CONSOLE. (fig. 4)**

Note Sequence

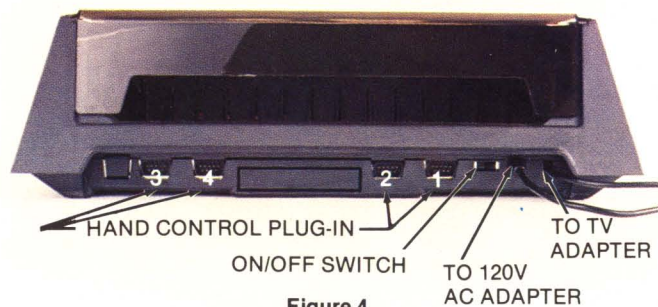

Figure 4

**V. SLIDE ON/OFF SWITCH TO THE ON POSITION.**

**VI. RF UNIT**

The RF unit is contained in the compartment on the left side panel. Before operating the Bally Professional

Arcade check that the RF unit is set to the correct operating channel, 3 or 4, whichever is not active in your area.

You may do this by noting the position of the switch. Set the channel select of the RF unit to a locally inactive channel. Thus if channel 4 is in use in your area the switch should be set to the channel 3 position. Reset the switch if necessary. (fig. 5)

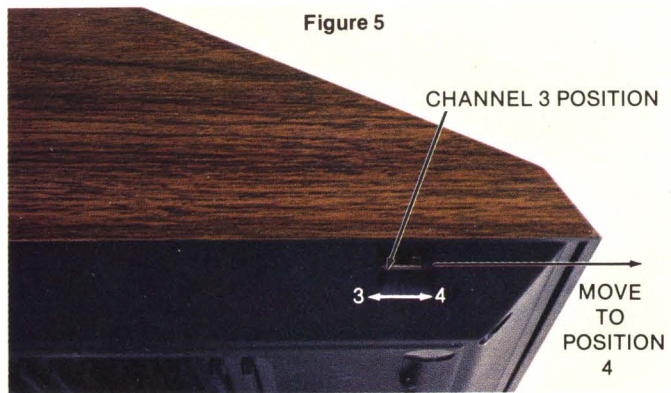

Once you have selected either channel 3 or 4 simply tune your television channel selector to that channel. (Please make sure the TV/game switch box selector is in the "Game" position.)

The menu should now appear on the screen.

You now have a choice of selecting Gunfight, Checkmate, Scribbling or Calculator. Press the appropriate numbered button on your keypad to start the game and to answer the additional questions the Bally Professional Arcade will ask.

## VII. YOUR TELEVISION RECEIVER MAY REQUIRE A FINE TUNING ADJUSTMENT IF THE PICTURE IS NOT CLEAR.

Adjust the fine tuning as follows:

1. Turn the AFC/AFT button to off to release the automatic fine tuning circuitry. (If your receiver is equipped with this feature, if not proceed to Step 2.)
2. Adjust the fine tuning knob clockwise until a herringbone pattern appears in the colored parts of the picture. Then turn the knob slowly counterclockwise and release it at the point where the herringbone pattern just disappears and the picture is clear. This is the correct tuning point.
3. Turn the AFC/AFT button to on in order to reactivate the automatic fine tuning circuits.

## VIII. COMPUTER WARM-UP INSTRUCTION

During the first few minutes of operation of your Bally Professional Arcade/Home Computer System, a random pattern may appear on your TV screen.

Should this occur, simply press the reset button to clear. In some rare instances, it may be necessary to turn the power switch off, then on again to completely clear the computer circuit.

Due to sophisticated computer circuitry operation, this condition may occur until the unit has reached its stable operating temperature.

## HAND CONTROL OPERATION

Each hand control is numbered on the top of its knob. Remember to insert each control into its corresponding numbered location on the back of your Arcade (see figure 4.)

The detailed action controlled by the hand controllers varies with the game being played. Each pistol grip hand control has several functions which determine the action seen on your screen.

Squeezing the trigger activates a switch for shooting as in Gunfight or placing a trace on the screen as in Scribbling.

The knob on top of the control can be moved in 8 directions, forward, backward, left right, and at 45 degree angles.

These motions determine the movement of the image angles.

Rotating this knob positions the cowboys hand during Gunfight, etc. Review hand control actions for each individual game. Notice the knob moves easily. **UNDER NO CIRCUMSTANCES SHOULD YOU FORCE THE KNOB.**

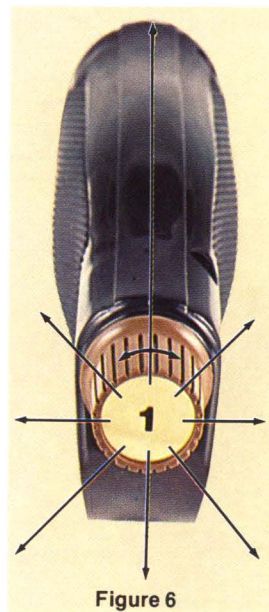

**Figure 6**

Top View

Hand Held

**Figure 7**





## GUNFIGHT™ (2 player only)

Gunfight is a very popular arcade game which has been included in your Bally Professional Arcade.

After you have made your connections and your unit has been turned on, press Reset and the following display should appear on your screen.



(Please refer to the section on adjustment if a different display appears or if the display is distorted.)

Press [1] on the keypad to play GUNFIGHT.

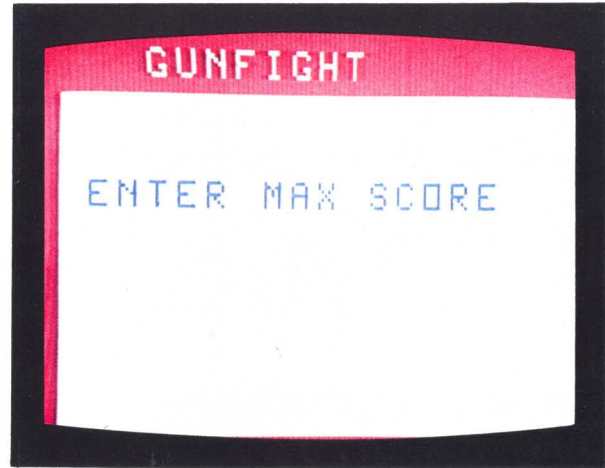

Using the keypad, enter the score you wish to play. (When playing to a score of less than 10, you must enter [=] to initiate play.)

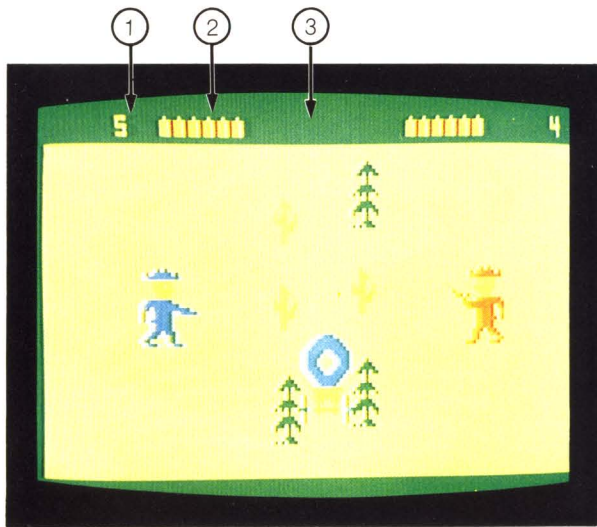

## HAND CONTROL FUNCTIONS

Gunfight is a two player game and utilizes hand controls #1 and #2.

Joy Stick . . . . . Walks your gunfighter around the screen.

Knob . . . . . Raises and lowers his arm.

Trigger . . . . . Shoots.

1. Each player's score
2. Bullets remaining
3. Ten second timer, not shown. (Starts when either player uses all six bullets.)
4. Each "scoring set" will have different objects appear on the screen between the gunfighters. Your gunfighter will be able to hide behind cacti, trees, and even a covered wagon.

## CHECKMATE (0 to 4 players)

Checkmate is another arcade game which is resident in your Professional Arcade.

With your unit turned on, press Reset and the following display should appear:



Press [2] on the keypad to play CHECKMATE.



Using the keypad, enter the number of games you wish to play. (When playing less than 10 games, you must enter [=] to initiate play.)

Enter (0) . . . . . The Professional Arcade plays by itself.  
Enter (1) . . . . . Four characters appear and you play against the Professional Arcade. You control symbol #1.



Enter 2, 3, or 4 . . . The corresponding number of symbols will appear.

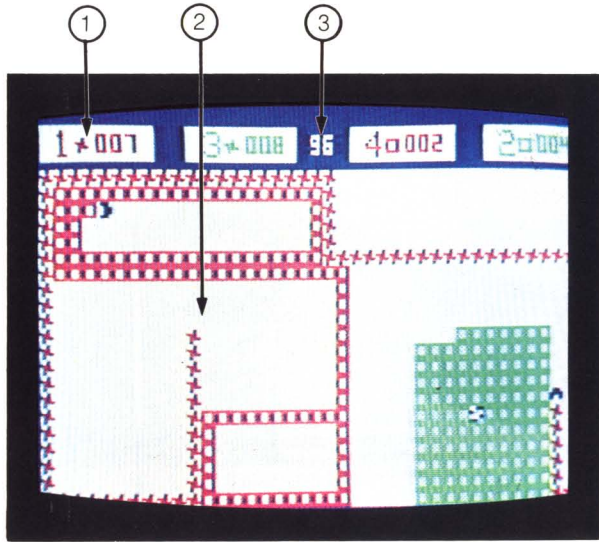

1. Each player's symbol and score.
2. Each player's symbol on the playing field.
3. The number of games remaining.

The object of Checkmate is to cause your opponent to crash into your trail, his own trail, or the sides of the playing field. Every time you out last one of your opponents, you receive one point. For example, in a game with four players, the first player to be eliminated scores zero, and the remaining three score one point each. The next player eliminated also scores zero, and the remaining two players each score another point. After all other players have been eliminated, the remaining player will have scored three points . . . and the game is over.

### HAND CONTROL FUNCTIONS

- Joy Stick . . . . . Moves your symbol horizontally, vertically, and diagonally.
- Knob . . . . . No function.
- Trigger . . . . . No function.

## SCRIBBLING

Scribbling is a fascinating, creative game. By manipulating the various controls you can create a multi-color pattern on your TV screen and draw or write almost anything you choose.



Press [4] on the keypad to play Scribbling.



Using the keypad, enter 0, 1, 2, 3, or 4 for the amount of people who wish to play.

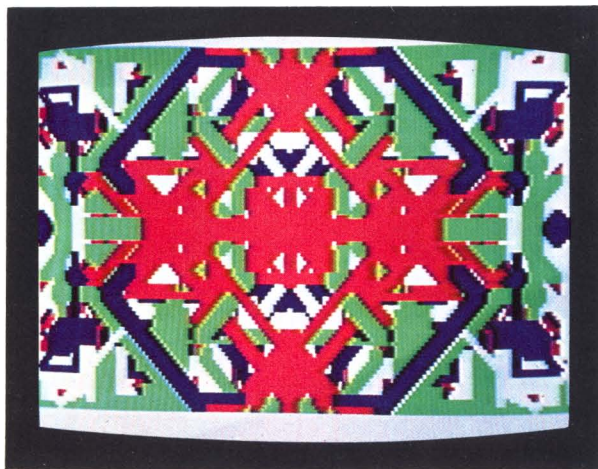

Place the plastic overlay provided with your unit over the keypad.

## HAND CONTROL FUNCTIONS

- Joy Stick . . . . . Moves cursor in eight directions.
- Knob . . . . . Turn counter clockwise to increase size of cursor and to change its color from white to green to red to blue.
- Trigger . . . . . Holding it in, places a trace on the screen as you move the joy stick.

There are 256 colors obtainable with Scribbling. To change the color of the picture displayed on your television, you must use the keys on the keypad as follows:

(Top to Bottom, Left to Right)

- Top Row . . . . . Changes colors to white, green, red, blue.
- Second Row . . . . . Reverses color changes of above.
- Third Row . . . . . Increases intensities.
- Fourth Row . . . . . Decreases intensities.
- Fifth Row . . . . . No function.
- Sixth Row . . . . . First key (clear) clears the screen; all others have no function.



## CALCULATOR

Not only does the Bally Professional Arcade contain three great games, but it also has a 5-function, 10-memory, printing calculator that will store and scroll up to 92 entries on your television screen.

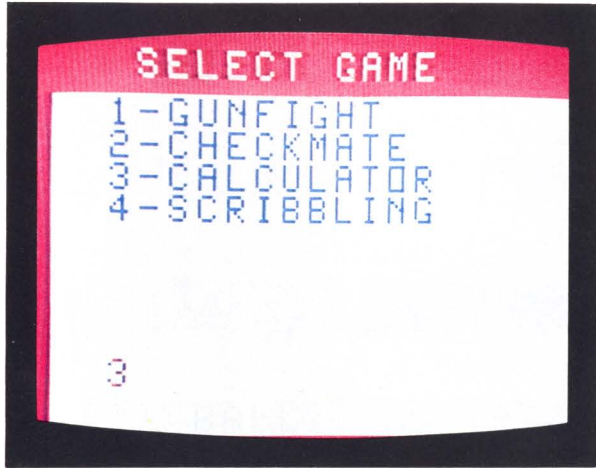

Enter [3] on your keypad to use the calculator.

The horizontal gold bar at the base of the screen will contain the present entry and answer.

This calculator functions as most others. You can add, subtract, multiply, divide, and figure percentage.

To familiarize yourself with the keypad, enter the following problem:

$$8 + 6 - 5 \times 16 \div 8$$

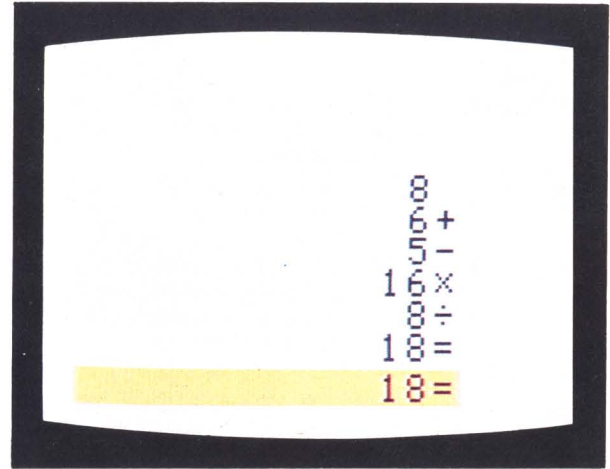

After you have performed the preceding calculation and have achieved the correct answer, continue calculations until you see the top entries of the first problem begin to slide off the screen. At this point press the scroll backward key ( $\downarrow$ ) until the top digit reappears. Now press the scroll forward key ( $\uparrow$ ) and return to the point you left off.

You can store up to 92 line entries on the "video" tape. Should your calculations exceed the 92 line limit, data at the beginning of the "video" tape will be omitted as new data is added.

## CALCULATOR FUNCTIONS

- (C) Clear Key— Removes all previous calculations including memory storage.
- (CE) Clear Entry— Removes only the last entry from display.
- (CH) Change Sign— The "CH" key changes the sign of the displayed number. Negative numbers will appear in red.
- (MS) Memory Store— Adds displayed number to memory, 10 individual entries to memory storage can be made. Each time the MS key is used it should be followed by pressing the appropriate number key (1, 2, 3, etc.), to establish numerical sequence within storage register.
- (MR) Memory Recall— Recalls number in memory to display. Must be followed by appropriate number key to secure correct memory from storage.
- (↑) Scroll Up— Moves video tape forward.
- (↓) Scroll Down— Moves video tape backward.
- (.) Decimal— Enters a decimal point.
- (%)— Calculates a percentage of the previous entry.



## WITH THE BALLY PROFESSIONAL ARCADE THERE'S ALWAYS MORE GAMES TO COME

### **ACTION SKILL SERIES**

Number 2001—280 Zzzap™  
Dodge™

2002—Sea Wolf™  
Missile

2003—Panzer Attack™  
Red Baron™

2004—Brickyard  
Clowns™

2005—Star Battle

### **SPORTS SERIES**

Number 3001—Tornado Baseball™  
Tennis  
Hockey  
Handball

3002—Football

3003—Demolition Derby  
Grand Prix

3004—Drag Race  
Desert Fox™

### **EDUCATION SERIES**

Number 4001—Bingo Math™  
Speed Math™

4002—Letter Match™  
Spell 'N' Score™  
Crosswords

4003—Astrology

### **STRATEGY SERIES**

Number 5001—Amazing Maze  
Tic Tac Toe

5002—Black Jack  
Poker  
Acey-Deucey

5003—Checkers  
Backgammon

### **FUNCTIONAL SERIES**

Number 6002—Bally Basic



## BALLY BASIC COMPUTER PROGRAMMING CASSETTE

The self-teaching system for making your own computer games, electronic music, and video art.

### COMPUTER GAMES

Your imagination is all you need to create your own fast action games. Play against your computer or challenge your friends to a game you make yourself.

### CHARTS AND GRAPHS

Make charts and graphs to display important information, forecast the performance of your favorite stock, or show the peaks in your household expenses.

### ELECTRONIC MUSIC

Play your favorite tune on your TV or compose your own music and hear it played by computer.

### VIDEO ART

Create endless patterns, designs, and intricate shapes. Experiment with motion, depth, and thousands of color combinations.

### BALLY BASIC INCLUDES:

- Computer programming cassette.
- Keypad with computer words, symbols, and complete alphabet.
- Complete programming instruction course.
- Library of educational programs, games, music, and art.

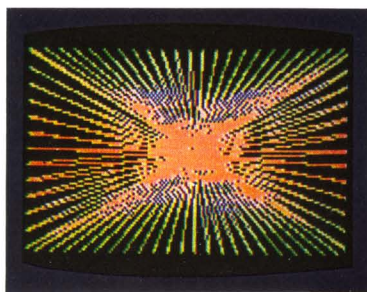

## AUDIO INTERFACE

Bally will soon offer an audio interface that will allow a personal cassette tape player to be connected to the Bally Professional Arcade. This will enable the user to save programs on audio tape and provide a permanent storage capability for *all* games, art, music and sound effects created by the individual.



LY MANUFACTURING CORPORATION • CONSUMER PRODUCTS DIVISION  
10750 W. GRAND AVE. • FRANKLIN PK., IL 60131  
CABLE ADDRESS MIDCO • TELEX NO. 72-1596