

GAME NOS. 873, 926 & 927  
FEBRUARY, 1981

# MIDWAY'S

# FIRE

# PARTS AND OPERATING MANUAL

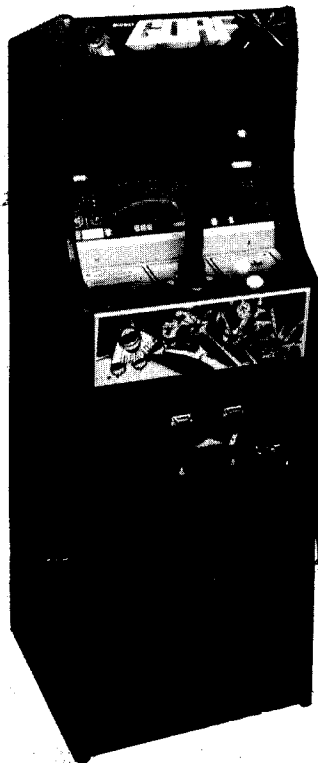

#926-MINI

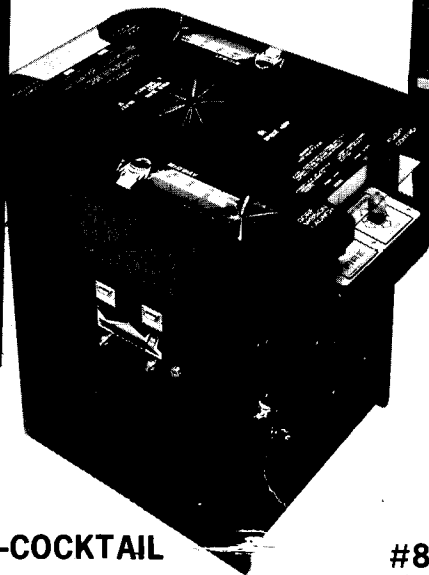

#927-COCKTAIL



#873-UPRIGHT



**MIDWAY MFG. CO.**

A BALLY COMPANY

10750 WEST GRAND AVENUE  
FRANKLIN PARK, ILLINOIS 60131  
U.S.A.

PHONE: (312) 451-1360

CABLE ADDRESS: MIDCO

TELEX NO.: 72-1596

FORM NO. 0873-00300-0000

# TABLE OF CONTENTS

---

	Page
GENERAL INSTRUCTIONS - UPRIGHT	2
GENERAL INSTRUCTIONS - MINI	3
CONTROL ADJUSTMENT PROCEDURE - UPRIGHT & MINI	4
GENERAL INSTRUCTIONS - COCKTAIL	5
SWITCH ADJUSTMENTS	6
TEST DISPLAY	7
NO. 873—GORF UPRIGHT - PHOTOGRAPH	8—10
INTERIOR ACCESS PICTURE - UPRIGHT	12—14
NO. 926—GORF MINI - PHOTOGRAPH	16—17
INTERIOR ACCESS PICTURE - MINI	18—19
PUSH BUTTON ASSEMBLY - UPRIGHT & MINI	20—21
CONTROL GRIP ASSEMBLY - UPRIGHT & MINI	22—23
NO. 927—GORF COCKTAIL - PHOTOGRAPH	24—25
INTERIOR ACCESS PICTURE - COCKTAIL	26—27
CONTROL SHELF ASSEMBLY - COCKTAIL	28—29
CONTROL ASSEMBLY - COCKTAIL	30—31
PUSH BUTTON ASSEMBLY - COCKTAIL	32—33
DOUBLE ENTRY COIN DOOR ASSEMBLY	34—35
COMMERCIAL CARD RACK ASSEMBLY	36—37
TRANSFORMER BOARD ASSEMBLY	38—39
WIRING DIAGRAM - UPRIGHT	41
WIRING DIAGRAM - MINI	42
WIRING DIAGRAM - COCKTAIL	43
POWER SUPPLY BOARD - COMPONENT LAYOUT	44
POWER SUPPLY BOARD - SCHEMATIC	45
DRIVER BOARD - COMPONENT LAYOUT	46
DRIVER BOARD - SCHEMATIC	47
R-G-B INTERFACE BOARD - COMPONENT LAYOUT	48
R-G-B INTERFACE BOARD - SCHEMATIC	49

## WARNING

**THIS GAME MUST BE GROUNDED. FAILURE TO DO SO MAY  
RESULT IN DESTRUCTION TO ELECTRONIC COMPONENTS.**

COPYRIGHT 1981 ©BY MIDWAY MFG. CO. ALL RIGHTS RESERVED.

NO PART OF THIS PUBLICATION MAY BE REPRODUCED BY ANY MECHANICAL, PHOTOGRAPHIC, OR ELECTRONIC PROCESS, OR IN THE FORM OF A PHONOGRAPHIC RECORDING, NOR MAY IT BE TRANSMITTED, OR OTHERWISE COPIED FOR PUBLIC OR PRIVATE USE, WITHOUT PERMISSION FROM THE PUBLISHER.

FOR PERMISSION REQUESTS, WRITE: MIDWAY MFG. CO., 10750 W. GRAND AVE., FRANKLIN PARK, IL 60131

# TABLE OF CONTENTS

---

	Page
CONTROL GRIP BOARD - COMPONENT LAYOUT	50
CONTROL GRIP BOARD - SCHEMATIC	51
DISPLAY BOARD - COMPONENT LAYOUT	52
DISPLAY BOARD - SCHEMATIC	53
AUDIO AMPLIFIER BOARD - COMPONENT LAYOUT	54
AUDIO AMPLIFIER BOARD - SCHEMATIC	55
RAM BOARD - COMPONENT LAYOUT	56
RAM BOARD - SCHEMATIC	57
CPU BOARD - COMPONENT LAYOUT	58
CPU BOARD - SCHEMATIC	59
PATTERN TRANSFER BOARD - COMPONENT LAYOUT	60
PATTERN TRANSFER BOARD - SCHEMATIC	61
ROM/RAM BOARD (DOMESTIC) - COMPONENT LAYOUT	62
ROM/RAM BOARD (DOMESTIC) - SCHEMATIC	63
ROM/RAM BOARD (FOREIGN) - COMPONENT LAYOUT	64
ROM/RAM BOARD (FOREIGN) - SCHEMATIC	65
GAME LOGIC BOARD - COMPONENT LAYOUT	66
GAME LOGIC BOARD - SCHEMATIC	67
19" MONITOR SCHEMATIC—WELLS GARDNER UPRIGHT & COCKTAIL	68
REPLACEMENT PARTS LIST	69—70
19" MONITOR SCHEMATIC - ELECTROHOME UPRIGHT & COCKTAIL	71
REPLACEMENT PARTS LIST	72—75
13" MONITOR SCHEMATIC - ELECTROHOME - MINI	76
REPLACEMENT PARTS LIST	77—80
MONITOR ADJUSTMENTS—WELLS GARDNER	81—82
MONITOR ADJUSTMENTS - ELECTROHOME	83—85
PRINTED CIRCUIT BOARD CHIP NUMBERS & FUNCTION	86—87
STRAPPING CHART	88

---

**WARNING:** This equipment Generates, Uses and can Radiate Radio Frequency Energy and if not installed and used in accordance with the Instructions Manual, may cause interference to Radio Communications. As temporarily permitted by Regulation it has not been tested for compliance to Subpart J or Part 15 of FCC Rules, which are designed to provide reasonable protection against such interference. Operation of this equipment in a Residential Area is likely to cause interference in which case the user at his own expense will be required to take whatever measures may be required to correct the interference.

## GENERAL INSTRUCTIONS FOR GORF UPRIGHT

### INSTALLATION

1. Remove shipping cleats located on bottom of cabinet.
2. Install four (4) provided leg levelers to bottom of cabinet and level cabinet.
3. The power is controlled by a switch located on the top of the cabinet. Plug into A.C. only, 115 volts, 60 cycles.

### LINE VOLTAGE SAFETY SWITCH

A line voltage safety switch has been provided for your protection. It is located on the right rear side of the cabinet. When the back door is removed, it opens the circuit to the line voltage. To restore power (when servicing) pull switch fully out.

### VOLTAGE CONTROL POTS

Located on power supply board (P.C. A082-90411-A000) and are preset at the factory. These pots should not be tampered with unless the distributor service department is contacted.

### TO SERVICE CONTROL PANEL

1. Open coin box door.
2. Release two (2) clamps located above coin door opening.
3. Disconnect control cable jack before removing.

### VOLUME CONTROL

Located on audio amplifier P.C. board controls the volume of all sounds and may be varied as desired by rotating pot control.

The audio amplifier board is located inside the front door for easy access.

M051-00873-A003

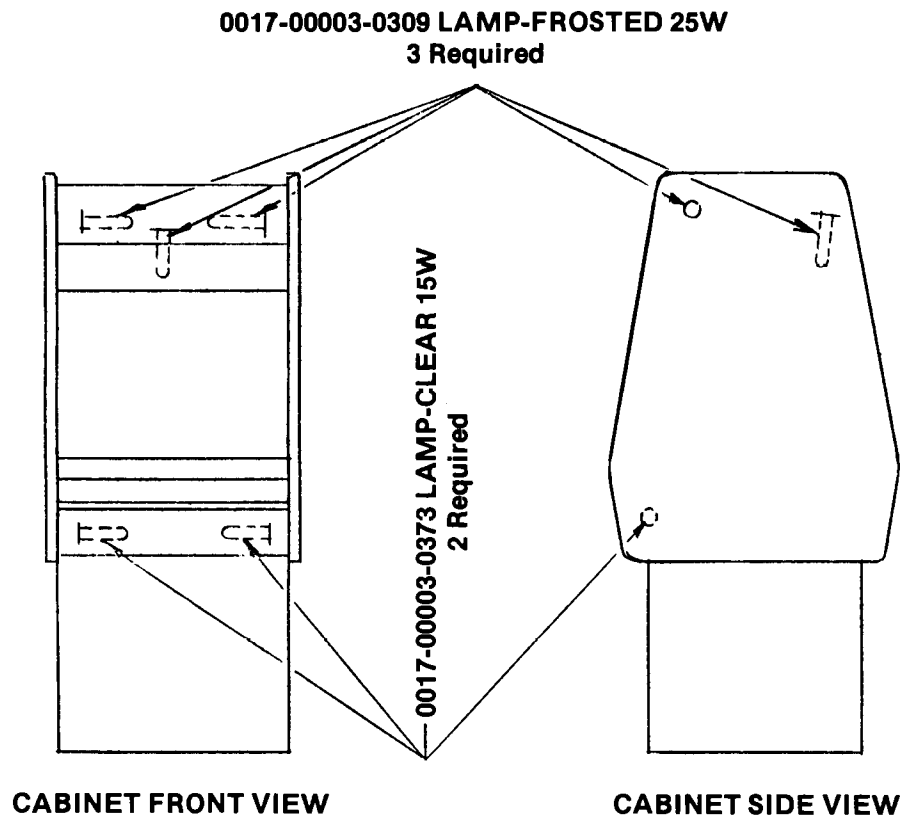

0873 GORF UPRIGHT LAMP LOCATION DRAWING

## **GENERAL INSTRUCTIONS FOR GORF MINI**

### **INSTALLATION**

1. Remove shipping cleats located on bottom of cabinet.
2. Install four (4) provided leg levelers to bottom of cabinet and level cabinet.
3. The power is controlled by a switch located on the back of the cabinet. Plug into A.C. only, 115 volts, 60 cycles.

### **LINE VOLTAGE SAFETY SWITCH**

A line voltage safety switch has been provided for your protection. It is located on the right rear side of the cabinet. When the back door is removed, it opens the circuit to the line voltage. To restore power (when servicing) pull switch fully out.

### **VOLTAGE CONTROL POTS**

Located on power supply board (P.C. A082-90411-A000) and are preset at the factory. These pots should not be tampered with unless the distributor service department is contacted.

### **TO SERVICE CONTROL PANEL**

1. Open coin box door.
2. Release two (2) clamps located below control panel on each side of cabinet.
3. Disconnect control cable jack before removing.

### **VOLUME CONTROL**

Located on audio amplifier P.C. Board controls the volume of all sounds and may be varied as desired by rotating pot control.

The audio amplifier board is located inside the front door for easy access.

M051-00926-A003

## CONTROL ADJUSTMENT PROCEDURE UPRIGHT & MINI

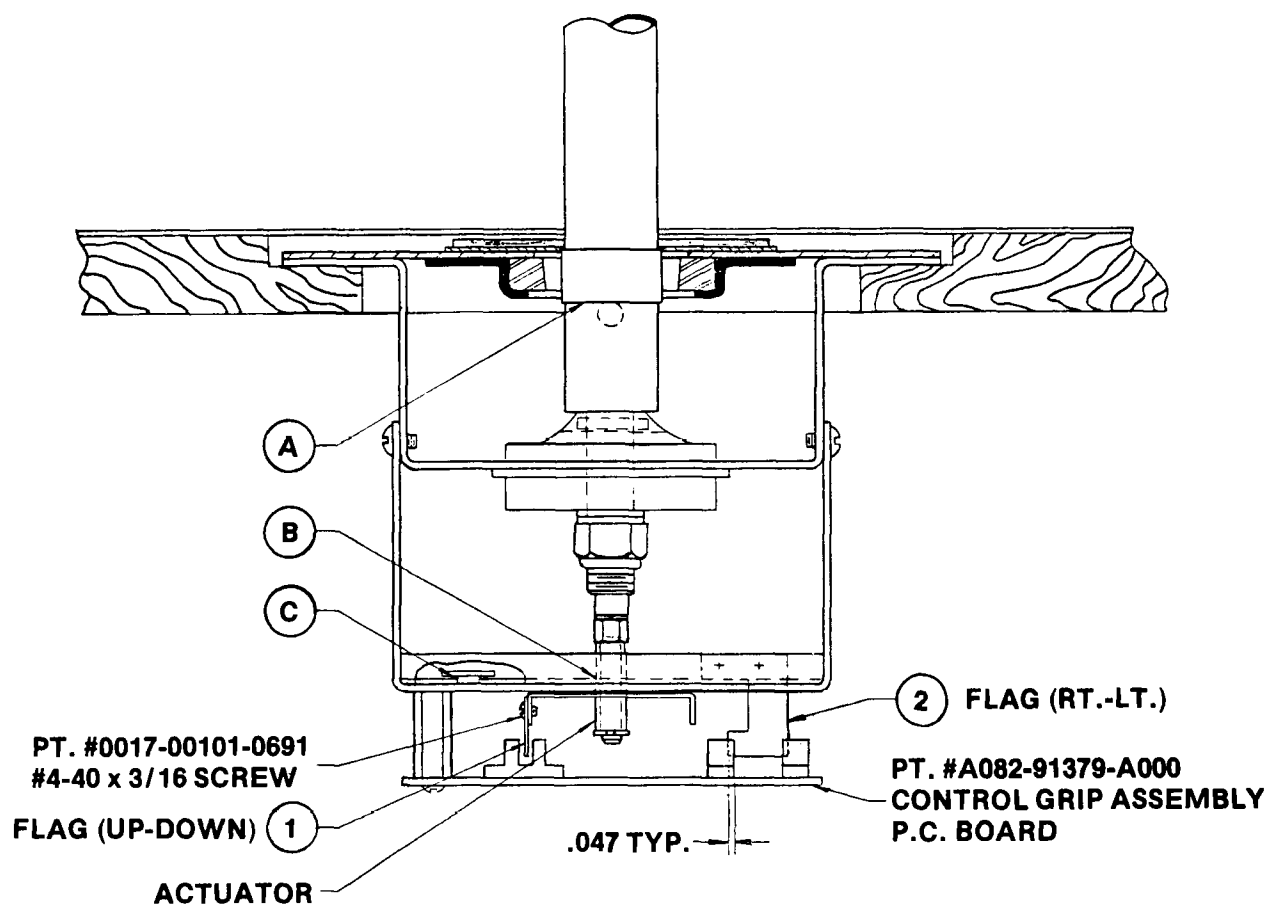

### NOTES:

1. ITEMS 1 AND 2 TO BE ADJUSTED WITH A GAGE SO THE SIDES ARE INSIDE THE SENSOR APPROX. .047 ON EACH SIDE OF SENSOR (AS SHOWN) WHEN ACTUATOR IS IN ITS FREE POSITION.
2. LUBRICATE AT POINT A, B, C, WITH GREASE MIDWAY PT. #0017-00008-0087.

## GENERAL INSTRUCTIONS FOR GORF COCKTAIL TABLE

### INSTALLATION

1. Remove shipping cleats located on bottom of cabinet.
2. Install four (4) provided leg levelers to bottom of cabinet and level cabinet.
3. The power is controlled by a switch located on the bottom of the cabinet below the first player. Plug into A.C. only, 115 volts, 60 cycles.

### LINE VOLTAGE SAFETY SWITCH

A line voltage safety switch has been provided for your protection. It is located in the cabinet on the left side of the coin door. When the coin door is opened, the circuit to the line voltage is interrupted. To restore power (when servicing) pull switch fully out.

### VOLTAGE CONTROL POTS

Located on power supply board (P.C. A082-90411-A000) and are preset at the factory. These pots should not be tampered with unless the Distributor Service Department is contacted.

### TO SERVICE CONTROL PANEL

1. Open coin box door.
2. Release two (2) clamps located above coin door opening.
3. Disconnect control cable jack before removing.

### VOLUME CONTROL

Located on audio amplifier P.C. board controls the volume of all sounds and may be varied as desired by rotating pot control.

The audio amplifier board is located inside the front door for easy access.

M051-00927-A003

### TO SERVICE MONITOR, GAME BOARD AND TRANSFORMER ASSY.

1. Open coin box door and release two (2) clamps indicated on sketch below.
2. Grasp monitor mounting panel at "A" and open as indicated in sketch below.

Caution: Due to the weight of the monitor extreme care must be exercised when opening cabinet for service.

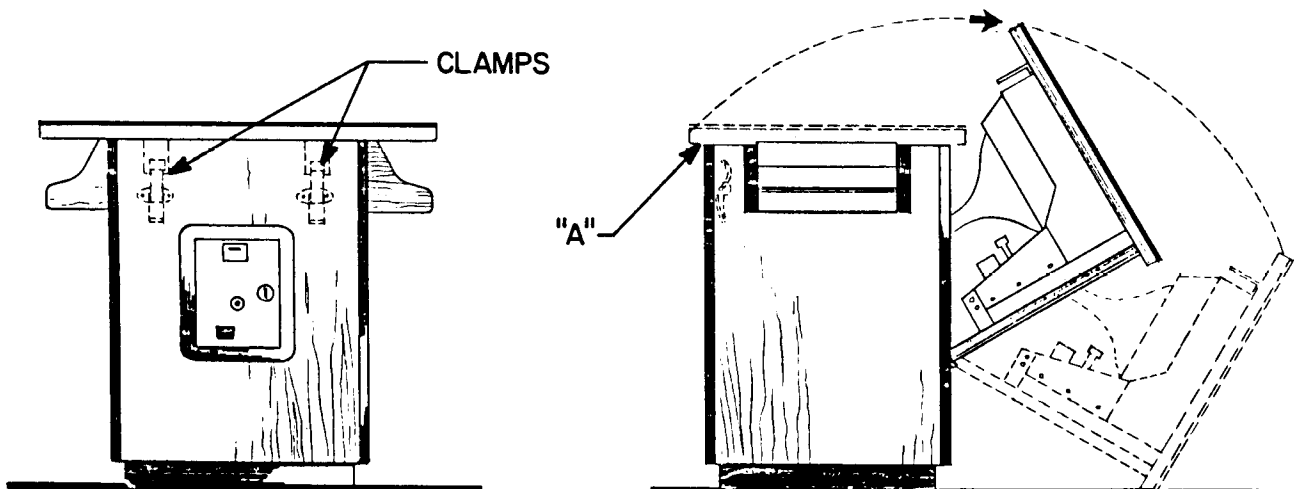

## LEFT COIN SLOT AND BASE ADJUSTMENT SWITCHES

### Switch 1

OFF  
1 Coin, 1 Player  
2 Coins, 1 Player  
2 Coins, 2 Players  
4 Coins, 2 Players

ON

2 Coins, 1 Player  
4 Coins, 1 Player  
4 Coins, 2 Players  
8 Coins, 2 Players

### Switch 5

OFF  
2 Bases  
4 Bases  
2 Bases each  
4 Bases each

2 Bases  
4 Bases  
2 Bases each  
4 Bases each

### Switch 5

ON  
3 Bases  
6 Bases  
3 Bases each  
6 Bases each

3 Bases  
6 Bases  
3 Bases each  
6 Bases each

## RIGHT COIN SLOT AND BASE ADJUSTMENT SWITCHES

### Switch 2

OFF

ON

### Switch 3

OFF  
1 Coin, 1 Player  
2 Coins, 1 Player  
2 Coins, 2 Players  
4 Coins, 2 Players

OFF

2 Coins, 1 Player  
4 Coins, 1 Player  
4 Coins, 2 Players  
8 Coins, 2 Players

### Switch 5

OFF  
2 Bases  
4 Bases  
2 Bases each  
4 Bases each

2 Bases  
4 Bases  
2 Bases each  
4 Bases each

### Switch 5

ON  
3 Bases  
6 Bases  
3 Bases each  
6 Bases each

3 Bases  
6 Bases  
3 Bases each  
6 Bases each

## LANGUAGE OPTION SWITCH

### Switch 4

OFF - English Language

ON - Foreign Language (requires A082-91374-A000)

## BONUS BASE ADJUSTMENT SWITCH

### Switch 6

OFF - Bonus Base awarded after Mission 5

ON - No Bonus Base awarded

## COIN/FREE PLAY SWITCH

### Switch 7

OFF - Coin Play

ON - Free Play (provided as service aid)

## ATTRACTION SOUNDS OPTION SWITCH

### Switch 8

OFF - Game attraction sound operate during game over

ON - Game attraction sounds do not operate during game over

ELECTRICAL BULLETIN: FOR ALL APPARATUS COVERED BY THE CANADIAN STANDARDS ASSOCIATION (CSA) STANDARD C22.2 NO. 1, WHICH EMPLOYS A SUPPLY CORD TERMINATED WITH A POLARIZED 2-PRONG ATTACHMENT PLUG.

CAUTION: TO PREVENT ELECTRIC SHOCK DO NOT USE THIS (POLARIZED) PLUG WITH AN EXTENSION CORD, RECEPTACLE OR OTHER OUTLET UNLESS THE BLADES CAN BE FULLY INSERTED TO PREVENT BLADE EXPOSURE.

ATTENTION: POUR PREVENIR CHOCS ELECTRIQUES NE PAS UTILISER CETTE FICHE POLARISEE AVEC UN PROLONGATEUR. UNE PRISE DE COURANT OU UNE AUTRE SORTIE DE COURANT, SAUF SI LES LAMES PEUVENT ETRE INSEREES A FOND SANS EN LAISSER AUCUNE PARTIE A DECOUVERT.



## TEST DISPLAY FOR GORF

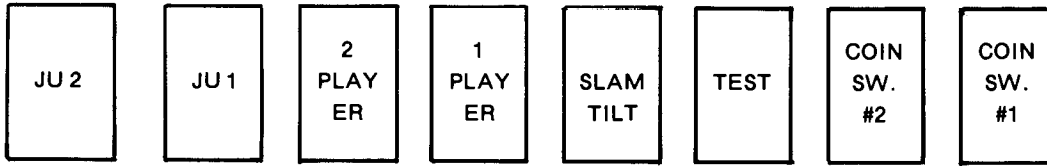

DISPLAY CAN  
BE SEEN



SW. OFF OR  
JUMPED NOT  
INSTALLED

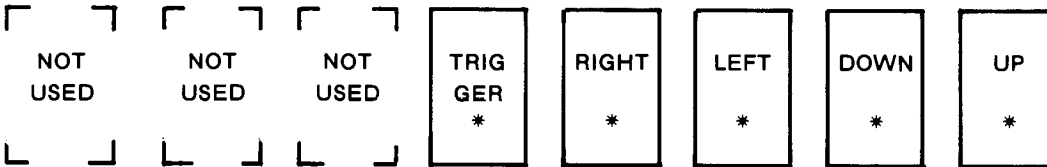

DISPLAY CANNOT  
BE SEEN

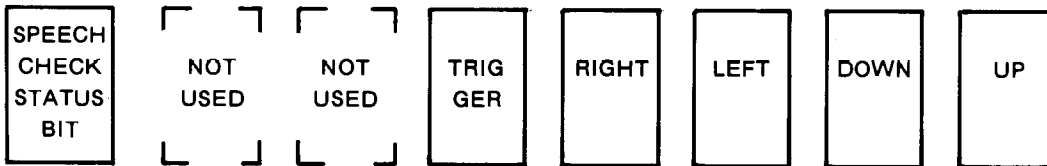

[ ]  
SW. ON OR  
JUMPER INSTALLED

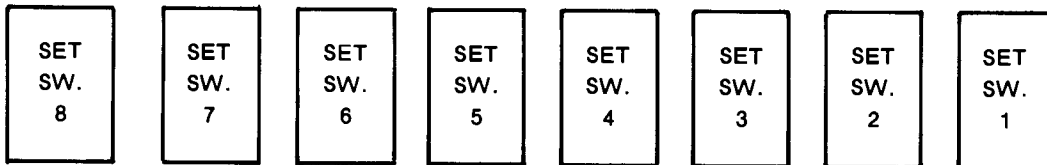

\* ACTIVATED BY  
2ND SET OF  
PLAYER CONTROLS,  
USED IN COCKTAIL  
CABINET ONLY

**A B C D E F G H**



**A LETTER APPEARING HERE INDICATES A BAD ROM/E PROM**

Placing the test switch (located on the Audio amplifier assy. in the coin box area) to "on" performs the following functions:

1. Removes all accumulated credits.
2. Test the screen rams.
3. Test the static rams.
4. Test all switches.

If a screen ram is defective random bars will flash on screen.

If a static ram is defective a random dotted pattern will flash on screen.

Dotted pattern will flash on the screen. If all rams are good the switch test pattern will appear on the screen.

All switches must be "off" to get the pattern shown above. When each switch is turned on the position of that switch will disappear.

Time delay between returning test switch to "off" and game over sequence is normal approx. 25 seconds.

**NO. 873 — GOLF UPRIGHT — PHOTOGRAPH**

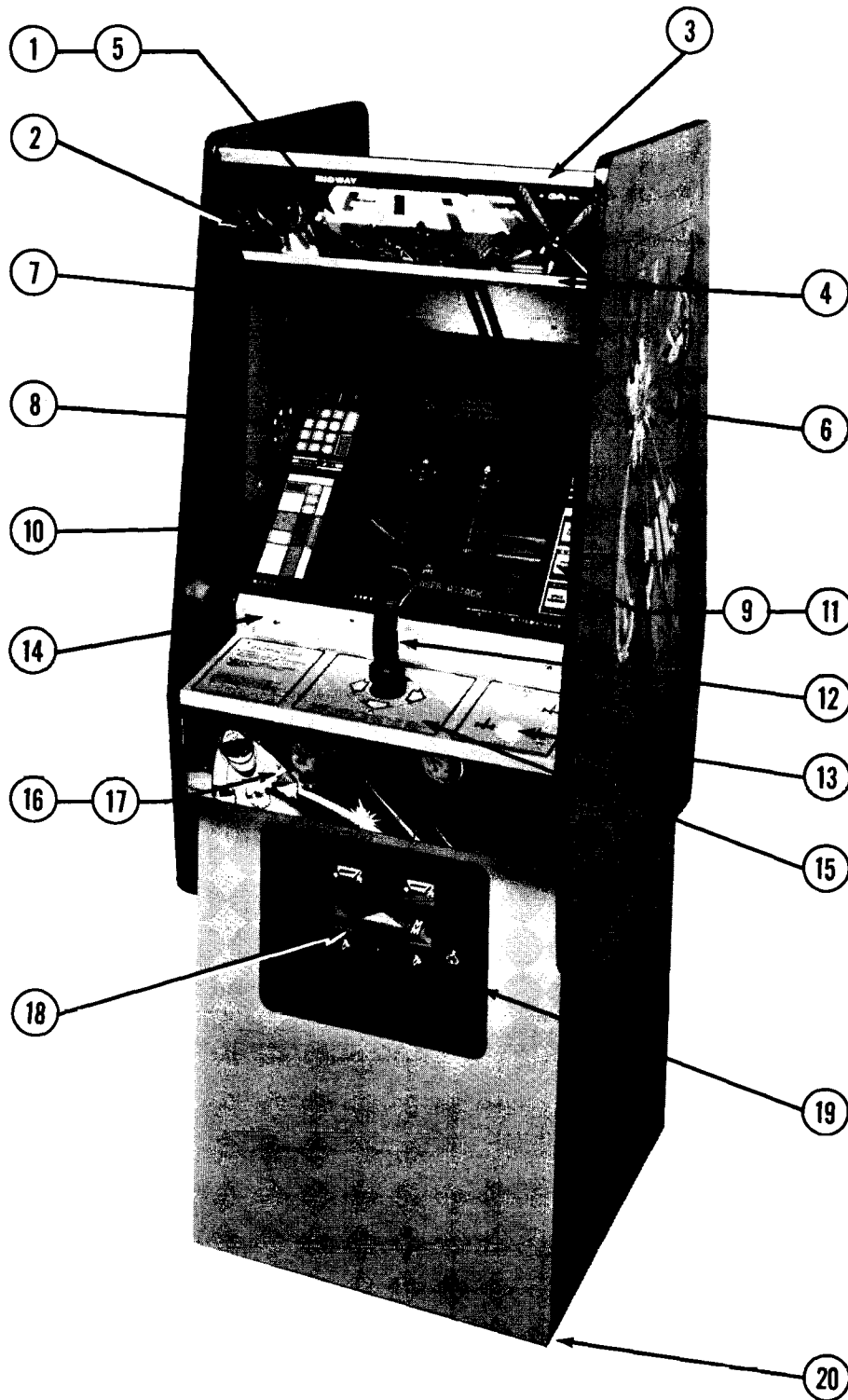

NO. 873 — GORF UPRIGHT — PHOTOGRAPH  
**ORDER BY PART NUMBER ONLY**

ITEM	PART N <sup>o</sup>	DESCRIPTION
1	0873-00905-00XF	ACRYLIC HEADER - 22-3/8" x 7-7/16" x 3/16"
2	0537-00903-0048	GLASS CHANNEL - 7-1/2" LG. (2 REQ'D.)
3	0873-00107-00XF	TOP HEADER BRKT. - 22-13/16" LG.
4	0873-00105-00XF	BOTTOM HEADER BRKT. - 22-13/16" LG.
5	0017-00101-0117	#8 x 5/8 PHIL. TRS. HD. S.M.S. (6 REQ'D.)
5	A873-00036-0000	TOP HEADER LIGHT ASSY.
5	0873-00103-0000	LIGHT FIXTURE BRKT. (2 REQ'D.)
5	0873-00912-0000	INSULATOR - FISHPAPER (2 REQ'D.)
5	0017-00101-0626	#8-32 x 3/4 SLT. PAN HD. M.S. (4 REQ'D.)
5	0017-00103-0061	#8-32 HEX NUT W/SEMS (4 REQ'D.)
5	0017-00003-0135	LAMP SOCKET #138 (2 REQ'D.)
5	0017-00003-0309	FROSTED LAMP 25W., 120V. (2 REQ'D.)
6	0873-00913-0000	DECAL (2 REQ'D.)
7	0873-00904-00XF	PLASTIC BACKGROUND SCENERY
7	0873-00104-0000	REAR SCENERY BRKT. - 8-3/8" LG. (2 REQ'D.)
7	0873-00101-00XF	GLASS BRKT. - 22-13/16" LG.
7	0873-00106-0000	REAR PLEXI BRKT.
7	0017-00101-0026	#8 x 5/8 SLT. HEX HD. S.M.S. (8 REQ'D.)
8	0873-00908-00XF	DECORATIVE SIDE PANEL - LEFT
8	0873-00908-01XF	DECORATIVE SIDE PANEL - RIGHT (NOT SHOWN)
8	0017-00007-0157	#4 CARPET TACK (6 REQ'D.)
9	0873-00903-00XF	DECORATIVE DISPLAY GLASS 22-5/16" x 20-7/8" x 1/8"
10	0905-00903-0200	GLASS EDGE CHANNEL - 19-7/8" LG. (2 REQ'D.)
11	A873-00014-0000	DISPLAY INSERT LIGHT ASSY.
11	0873-00914-0000	PLASTIC LIGHT INSERT
11	0017-00031-0029	WEDGE BASE LAMP SOCKET #1532 (6 REQ'D.)
11	0017-00003-0218	LAMP #161 - 14V., .19A. (6 REQ'D.)
11	A084-91376-A873	DISPLAY BOARD ASSEMBLY
11	0873-00125-0000	LIGHT INSERT BRKT.
11	0017-00101-0642	#8-32 x 1-1/2 CARRIAGE BOLT (2 REQ'D.)
11	0017-00103-0061	#8-32 HEX NUT W/SEMS (2 REQ'D.)
11	0017-00101-0018	#6 x 3/4 SLT HEX HD. M.S. (2 REQ'D.)
12	A873-00005-0000	CONTROL GRIP ASSEMBLY
13	A739-00012-0000	PUSH BUTTON ASSY. (2 REQ'D.)

NO. 873 — GORF UPRIGHT — PHOTOGRAPH  
**ORDER BY PART NUMBER ONLY**

ITEM	PART No	DESCRIPTION
14	0873-00112-00XF 0017-00101-0764 0017-00104-0023	GLASS HOLD DOWN BRKT. #10-32 TRUSS HD. SCR. (3 REQ'D.) #10 EXT. WASHER (3 REQ'D.)
15	0873-00119-00XF 0017-00101-0118 0017-00104-0030 0017-00103-0061	CONTROL PLATE - DECORATIVE #8-32 x 1-1/16 CARRIAGE BOLT (6 REQ'D.) #8 WASHER (6 REQ'D.) #8-32 HEX NUT W/SEMS (6 REQ'D.)
16	0873-00907-00XF 0873-00111-0000 0017-00101-0597	BOTTOM DECORATIVE HEADER HEADER BRKT. #8-32 x 5/16 SLT. HEX HD. SCR. (8 REQ'D.)
17	A873-00016-0000 0873-00108-0100 0873-00912-0000 0017-00101-0626 0017-00103-0061 0017-00003-0135 0017-00003-0373	BOTTOM HEADER LIGHT ASSY. LIGHT FIXTURE BRKT. (2 REQ'D.) INSULATOR - FISHPAPER (2 REQ'D.) #8-32 x 3/4 SLT. PAN HD. M.S. (4 REQ'D.) #8-32 HEX NUT W/SEMS (4 REQ'D.) LAMP SOCKET #138 (2 REQ'D.) CLEAR LAMP 15W., 120V. (2 REQ'D.)
18	A090-00076-02BK	DOUBLE ENTRY COIN DOOR ASSY.
19	0090-00002-02BK 0017-00101-0121	COIN DOOR FRAME #6-32 x 5/16 PHIL. TRS. HD. SCR. (3 REQ'D.) (MOUNTS COIN DOOR TO FRAME)
20	0017-00102-0048 0017-00103-0026	3/8-16 x 2'' LEG LEVELERS (4 REQ'D.) 3/8-16 LEG LEVELER HEX NUT (4 REQ'D.)
	0017-00003-0187 0151-00011-0000 0017-00101-0639 0017-00103-0061 A873-00035-0000 0873-00906-0000 0935-00904-0000	<b><u>NOT SHOWN LIST</u></b> SPEAKER - 6'' x 9'', 8 OHM, 9W. (2 REQ'D.) SPEAKER GRILL (2 REQ'D.) #8-32 x 1-1/4 CARRIAGE BOLT (8 REQ'D.) #8-32 HEX NUT W/SEMS (8 REQ'D.) BEZEL ASSY. BEZEL SMOKED PLEXI-GLASS

# NOTES

---

This space is provided for personal notes

NO. 873 — GORF UPRIGHT — INTERIOR ACCESS PICTURE

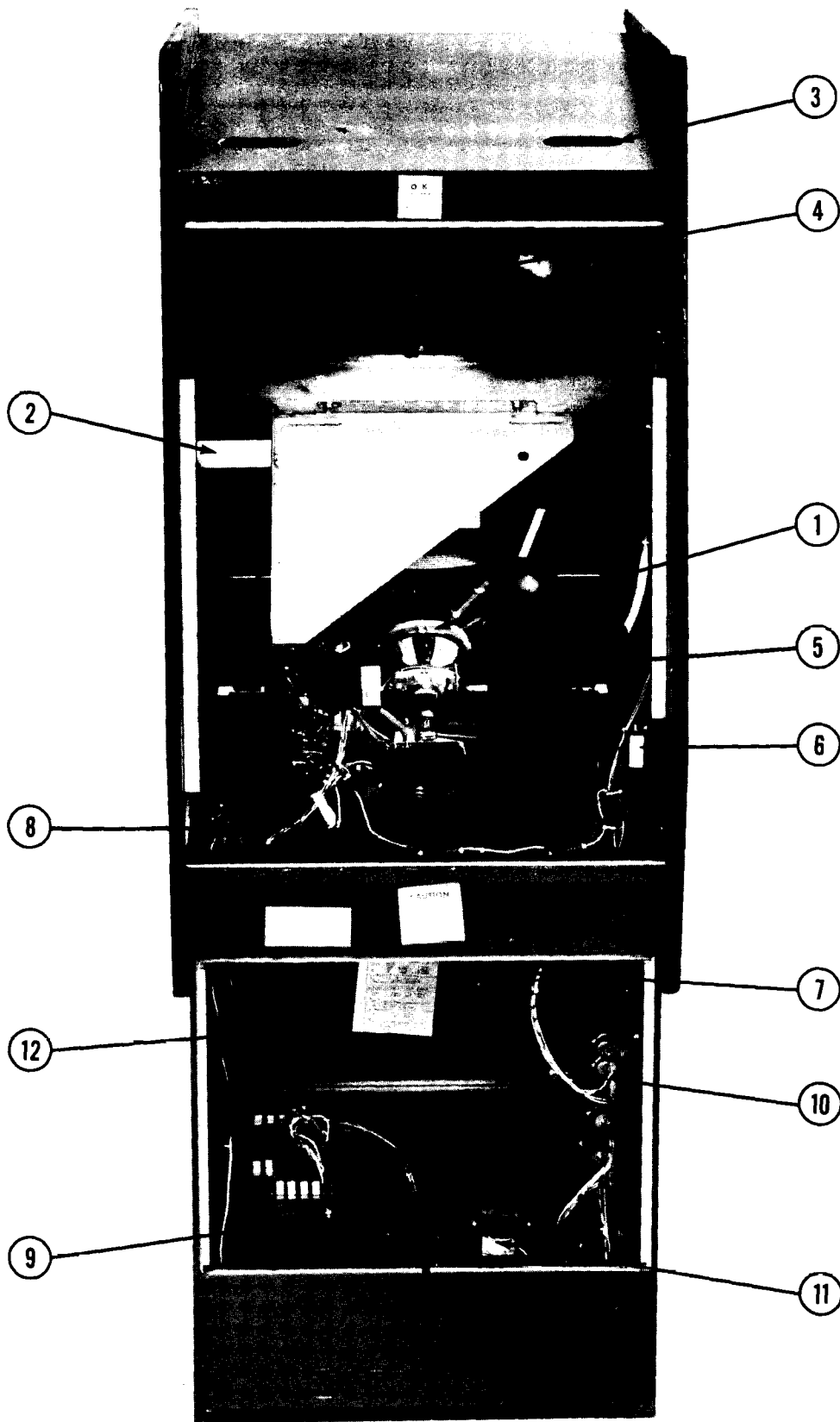

NO. 873 — GORF UPRIGHT — INTERIOR ACCESS PICTURE

*ORDER BY PART NUMBER ONLY*

ITEM	PART NO	DESCRIPTION
1	0017-00003-0339	ELECTROHOME 19" COLOR DUAL SYNC
1	0017-00003-0354	HORIZ. MTG. MONITOR (OR) WELLS-GARDNER 19" COLOR DUAL
2	0873-00110-0000	SYNC HORIZ MTG. MONITOR
	0873-00121-0000	MONITOR BRKT.
	0017-00102-0012	TOP MONITOR BRKT.
	0017-00104-0014	1/4-20 x 1-1/4 UNSLOT. HEX HD. BOLT (4 REQ'D.)
	0017-00103-0018	PERIPHERY WASHER (4 REQ'D.)
3	0017-00032-0083	1/4-20 HEX NUT (4 REQ'D.)
	0567-00106-0100	ON-OFF SWITCH W/NUT
	0017-00101-0028	SWITCH PLATE
4	A873-00013-0000	#8 x 3/4 HEX HD. SCR. (4 REQ'D.)
	0873-00103-0000	LIGHT ASSY.
	0017-00101-0626	LIGHT BRKT.
	0017-00103-0061	#8-32 x 3/4 SLT. PAN HD. M.S. (2 REQ'D.)
	0017-00003-0135	#8-32 HEX NUT W/SEMS (2 REQ'D.)
	0017-00003-0309	LAMP SOCKET #138
5	0017-00009-0033	FROSTED LAMP 25W., 120V.
	0603-00131-0000	BASSICK CLAMP (2 REQ'D.)
	0017-00101-0028	STRIKE (2 REQ'D.)
6	A151-00027-0000	#8 x 3/4 SLT. HEX HD. SCR. (4 REQ'D. - CLAMP, 4 REQ'D. - STRIKE)
	0017-00101-0026	INTERLOCK SW. & BRKT. ASSY.
7	0902-00108-0000	#8 x 5/8 HEX HD. S.M.S. (2 REQ'D.)
	A082-90903-A000	AUDIO AMPL. BRKT. - HEATSINK
	0017-00003-0205	AUDIO AMPL. BRD. ASSY. - STEREO
	0017-00101-0107	MICA INSULATOR (2 REQ'D.)
	0017-00007-0153	#6 x 5/16 SLT. HEX HD. SCR. (4 REQ'D.)
	0017-00042-0014	P.C. BRD. SUPPORT (4 REQ'D.)
	0017-00101-0716	HEYCO NUT 1/4" (3 REQ'D.)
	0017-00103-0060	#6-32 x 1/4 SLT. RND. HD. M.S. (2 REQ'D.)
8	A082-91363-A000	#6-32 HEX NUT (2 REQ'D.)
	0017-00101-0018	R-G-B INTERFACE P.C. BRD. ASSY.
9	A873-00009-0000	#6 x 3/4 SLT. HEX HD. SCR. (4 REQ'D.)
		CARD RACK ASSY. W/P.C.B.'S

NO. 873 — GORF UPRIGHT — INTERIOR ACCESS PICTURE

*ORDER BY PART NUMBER ONLY*

ITEM	PART NO	DESCRIPTION
10	A082-90411-A000 0624-00902-0100 0624-00902-0300 0017-00104-0037 0017-00101-0028	POWER SUPPLY BRD. ASSY. P.C. SUPPORT BRKT - 12'' LG. (2 REQ'D.) P.C. SUPPORT BRKT. - 2-1/2'' LG. (2 REQ'D.) 1/16 THK. FLAT WASHER (10 REQ'D.) #8 x 3/4 HEX HD. SCR. (10 REQ'D.)
11	A873-00010-0000	TRANSFORMER BRD. ASSY.
12	0017-00009-0477 A905-00026-0000 A624-00001-0000 0624-00101-0000 0017-00101-0628 0017-00104-0022 0017-00103-0061	CASH BOX - MOLDED CASH BOX COVER ASSY. CASH BOX GUIDE BRKT. ASSY. CASH BOX GUIDE BRKT. #8-32 x 3/4 CARRIAGE BOLT (4 REQ'D.) #8 FLAT WASHER (4 REQ'D.) #8-32 HEX NUT W/SEMS (4 REQ'D.)
	0017-00004-0022 0926-00904-0000 0017-00101-0579 0017-00104-0017 0017-00103-0005 0017-00009-0490 A151-00029-0000	<p><u>NOT SHOWN LIST</u></p> <p>304 DYMAX STRAP PROTECTIVE BUBBLE - UPPER BACK DOOR #6-32 x 1'' CARRIAGE BOLT (10 REQ'D.) #6 FLAT WASHER (10 REQ'D.) #6-32 HEX NUT W/SEMS (10 REQ'D.) 5-5/8 SQ. VENT GRILL (4 REQ'D.) BACK DOOR LOCK ASSY. (2 REQ'D.)</p>



# NOTES

---

This space is provided for personal notes

NO. 926 — GORF MINI — PHOTOGRAPH

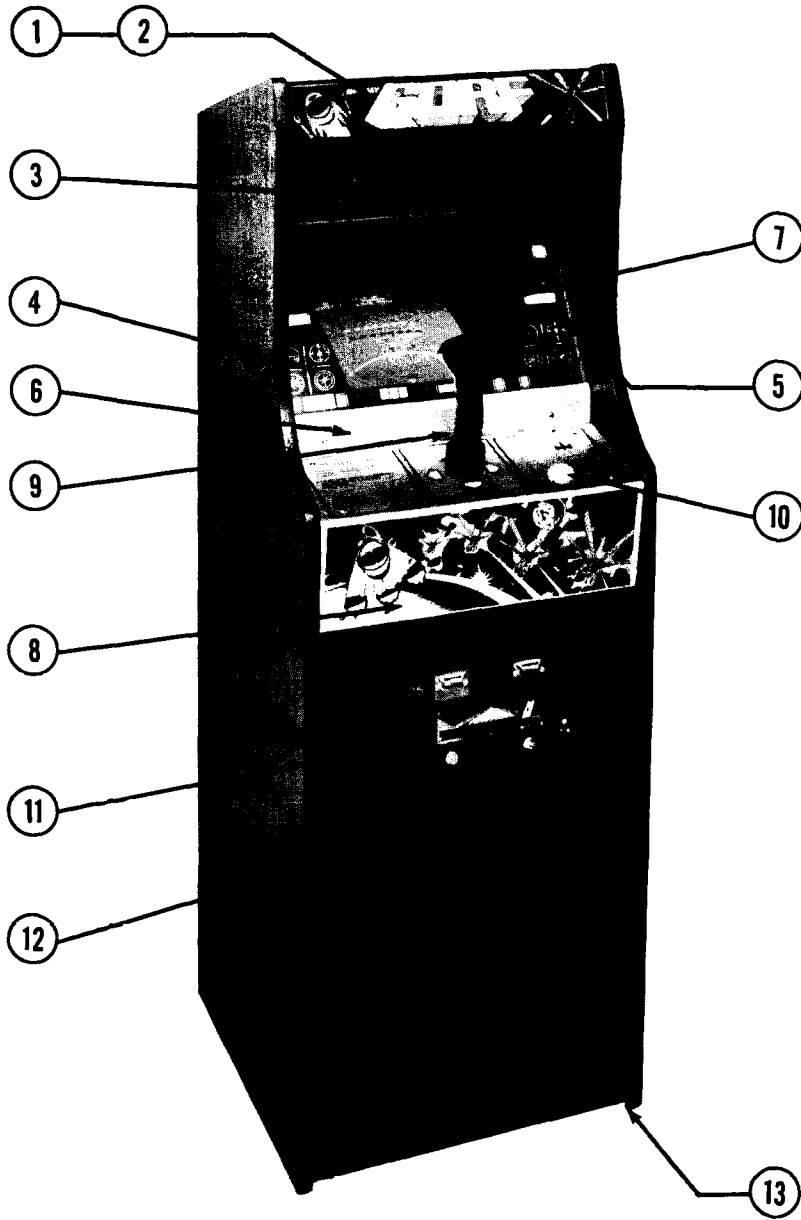

**ORDER BY PART NUMBER ONLY**

ITEM	PART NO	DESCRIPTION
1	0926-00903-0000	DISPLAY PLEX
	0017-00101-0117	#8 x 5/8 PHIL. TRUSS HD. SCREW (8 REQ'D.)
2	A926-00010-0000	INSERT DISPLAY ASSY.
	0017-00031-0030	LIGHT SOCKET (5 REQ'D.)
	0017-00003-0219	LAMP #194 14V .27A WEDGE (5 REQ'D.)
3	0017-00003-0161	SPEAKER 4" SQ. 8 OHM 3W (2 REQ'D.)
	0017-00009-0482	SPEAKER GRILL (2 REQ'D.)
	0017-00101-0127	#8-32 x 1-3/8 CARRIAGE BOLT (8 REQ'D.)
	0017-00103-0061	#8-32 HEX NUT W/SEMS (8 REQ'D.)
4	0926-00901-00XF	MAIN GLASS
5	0905-00903-0300	GLASS CHANNEL 11-3/4 (2 REQ'D.)
6	0926-00103-00XF	GLASS CLAMPING PLATE
	0017-00101-0760	#10-32 x 1" PHIL. RND. HD. W/WASHER (2 REQ'D.)
7	0926-00905-0000	T.V. BEZEL
	0926-00902-0000	PLEXI GLASS
8	0926-00102-00XF	CONTROL PLATE
	0017-00101-0118	#8-32 x 1-1/8 CARRIAGE BOLT (4 REQ'D.)
	0017-00104-0030	#8 FLAT WASHER (4 REQ'D.)
	0017-00103-0061	#8-32 HEX NUT W/SEMS (4 REQ'D.)
	0017-00101-0065	#6 x 1/2 PHIL. TRUSS HD. SCREW (2 REQ'D.)
9	A873-00005-0000	CONTROL GRIP ASSY.
10	A739-00012-0000	PUSH BUTTON ASSY. (2 REQ'D.)
11	A090-00076-02BK	FRONT DOOR ASSY.
	A090-00057-0000	COUNTER METER ASSY.
12	0090-00002-02BK	COIN DOOR FRAME
	0017-00101-0121	#6-32 x 5/16 PHIL. TRS. HD. SCREW (3 REQ'D.) (MOUNTS COIN DOOR TO FRAME)
13	0017-00102-0048	LEG LEVELERS (4 REQ'D.)
	0017-00103-0026	LEG LEVELER NUTS (4 REQ'D.)
		<b>NOT SHOWN LIST</b>
	0017-00009-0033	BASSICK CLAMP (2 REQ'D.)
	0603-00131-0000	STRIKE (2 REQ'D.)
	0017-00101-0028	#8 x 3/4 SLT. HEX SCREW (4 REQ'D. CLAMP - 4 REQ'D. STRIKE)

NO. 926 — GORF MINI — INTERIOR ACCESS PICTURE

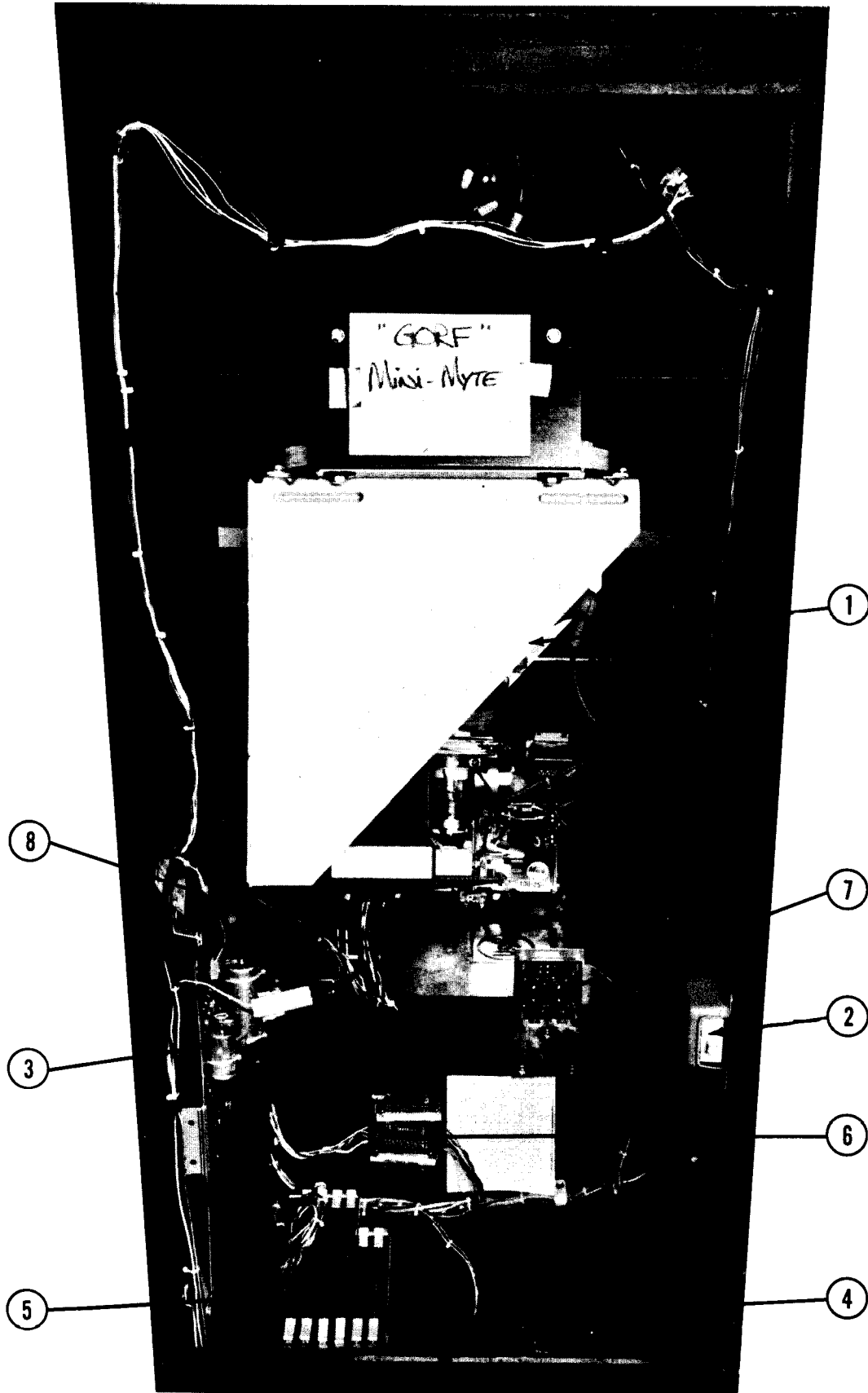

NO. 926 — GOLF MINI — INTERIOR ACCESS PICTURE  
***ORDER BY PART NUMBER ONLY***

ITEM	PART NO	DESCRIPTION
1	0017-00003-0340	13" COLOR DUAL SYNC HORIZ. MTG. MONITOR - ELECTROHOME
		(OR)
1	0017-00003-0369	13" COLOR DUAL SYNC HORIZ. MTG. MONITOR - WELLS-GARDNER
	A926-00012-00XF	T.V. MTG. BRKT ASSY.
	0017-00101-0628	#8-32 x 3/4 CARRIAGE BOLT (4 REQ'D.)
	0017-00104-0026	#8 FLAT WASHER (4 REQ'D.)
	0017-00103-0061	#8-32 HEX NUT W/SEMS (4 REQ'D.)
2	A151-00027-0000	INTERLOCK SWITCH & BRKT. ASSY.
	0017-00101-0028	#8 x 3/4 SLT. HEX HD. WD. SCR. (2 REQ'D.)
3	A082-90411-A000	POWER SUPPLY P.C.B.
	0624-00902-0100	P.C. SUPPORT BRKT. 12" (2 REQ'D.)
	0624-00902-0300	P.C. SUPPORT BRKT. 2-1/2" (2 REQ'D.)
4	A873-00010-0000	TRANSFORMER BD. ASSY.
5	A789-00002-0000	CARD RACK ASSY.
6	A082-91363-A000	R-G-B INTERFACE P.C.B. ASSY.
7	A082-90903-A000	AUDIO AMP P.C.B. ASSY. STEREO
8	A905-00028-0000	CASH BOX ASSY. W/HANDLE
	0905-00126-00XF	CASH BOX HANDLE
	A905-00026-0000	CASH BOX COVER ASSY.
	A624-00001-0000	CASH BOX GUIDE BRKT. ASSY.
	0624-00101-0000	CASH BOX GUIDE BRKT.
		<b><u>ADDITIONAL PARTS LIST</u></b>
	A097-00003-0000	LOCK ASSY. - BACK DOOR
	0017-00009-0490	VENT GRILL (2 REQ'D.)
	0926-00904-0000	PROTECTIVE BUBBLE - BACK DOOR
	0017-00032-0083	ON-OFF SWITCH
	0567-00106-0100	ON-OFF SWITCH MTG. PLATE
	A082-90508-A000	DRIVER P.C.B. ASSY.
	A873-00023-0000	STEREO AUDIO AMP BD. & BRKT. ASSY.

**NO. 873 & 926 — GOLF UPRIGHT & MINI — PUSH BUTTON ASSEMBLY**

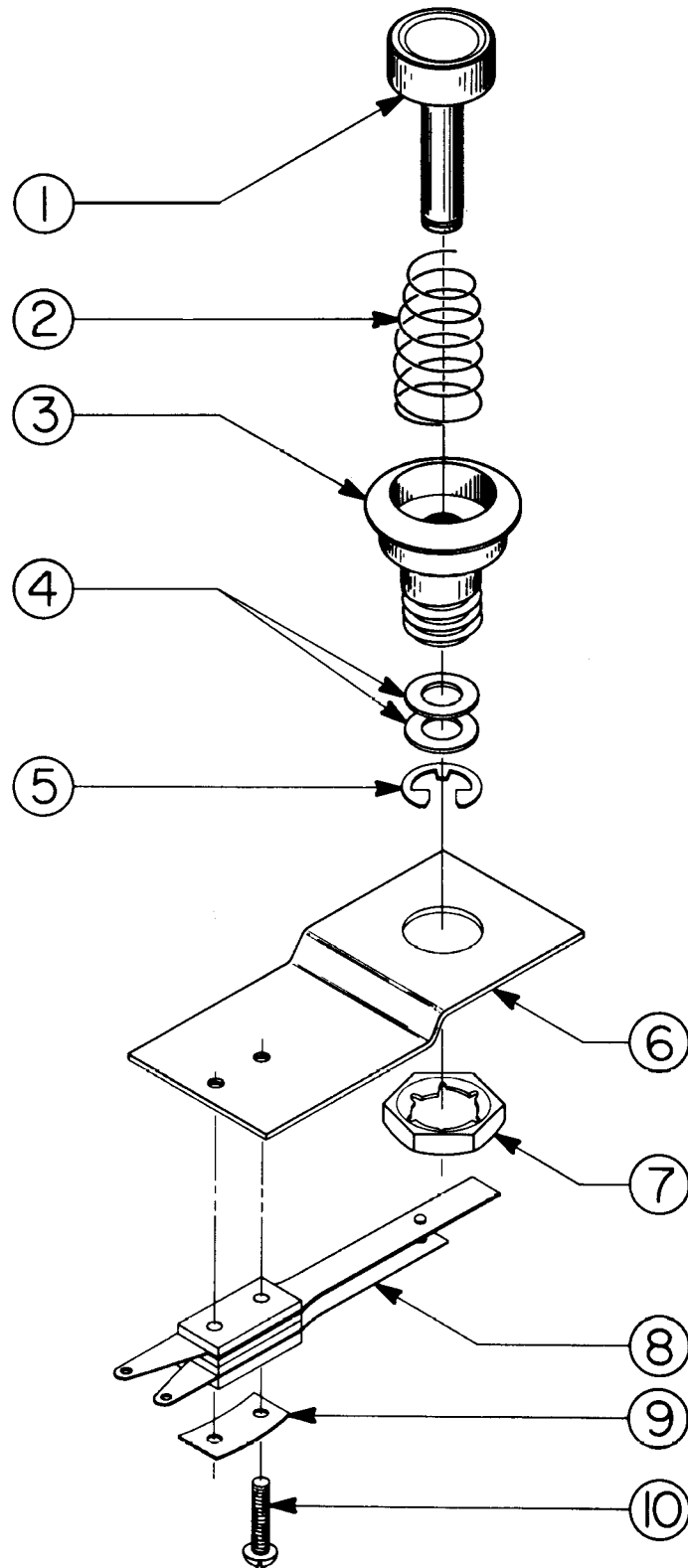

NO. 873 & 926 — GOLF UPRIGHT & MINI — PUSH BUTTON ASSEMBLY

*ORDER BY PART NUMBER ONLY*

ITEM	PART NO	DESCRIPTION
1	0017-00009-0384	BUTTON
2	0010-00593-0000	SPRING
3	0017-00009-0376	BUTTON HOUSING
4	0017-00104-0028	FLAT WASHER (2 REQ'D.)
5	0017-00100-0025	E-RING
	A739-00012-0000	PUSH BUTTON ASSY. (FIRST 5 ITEMS)
6	0586-00107-0000	MOUNTING BRKT.
7	0017-00103-0054	PAL NUT
8	A739-00016-0000	SWITCH ASSY.
9	0020-00202-0000	SWITCH PLATE
10	0017-00101-0526	#5-40 x 9/16 PHIL. HD. M.S. (2 REQ'D.)

**NO. 873 & 926 — GOLF UPRIGHT & MINI — CONTROL GRIP ASSEMBLY**

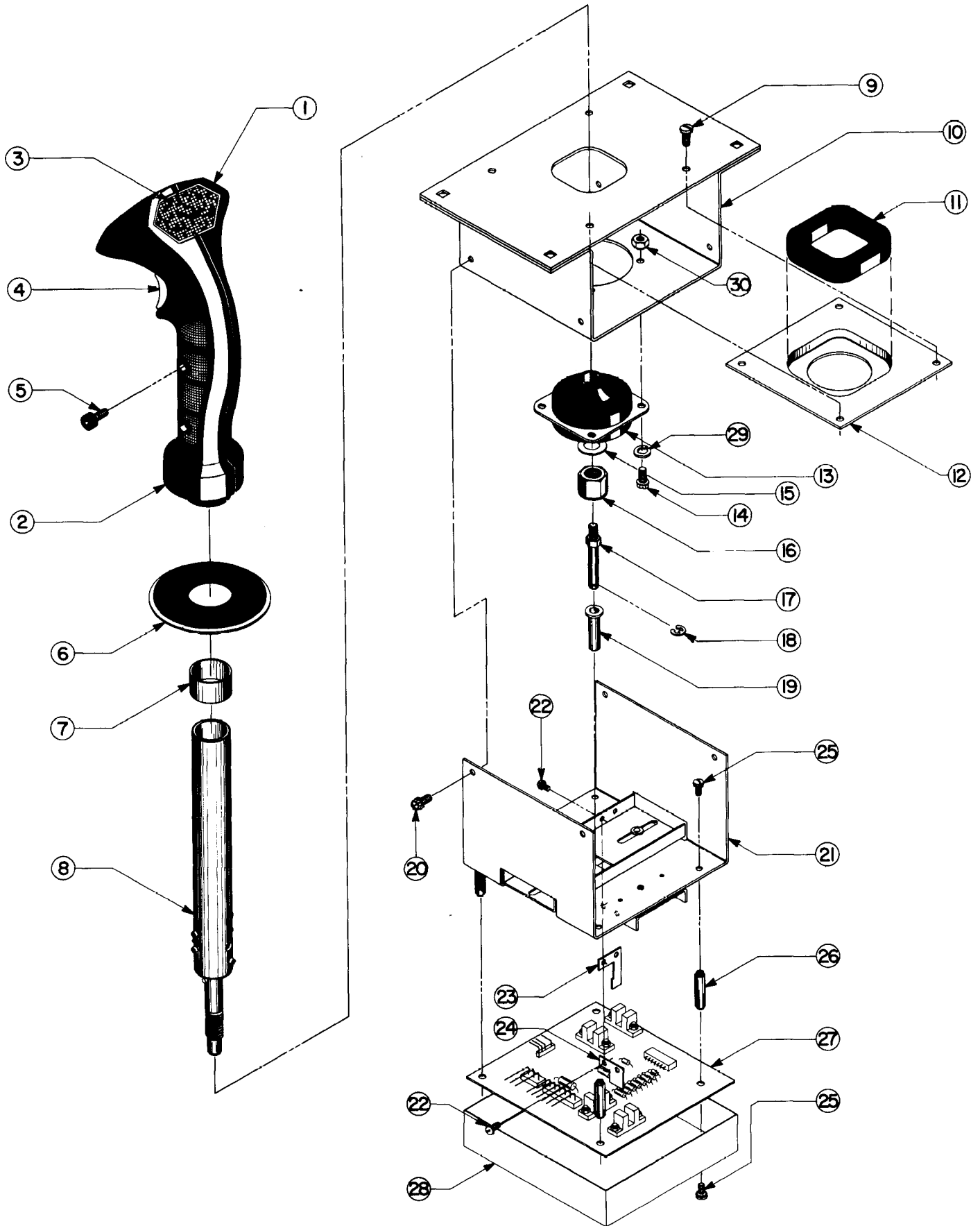



*ORDER BY PART NUMBER ONLY*

ITEM	PART NO	DESCRIPTION
1	0873-00900-0200	CONTROL GRIP - LEFT
2	0873-00900-0100	CONTROL GRIP - RIGHT
3	0873-00902-0000	CONTROL GRIP LENS PANEL
	0017-00003-0364	WEDGE BASE LAMP .08 AMP, 14V. (2 REQ'D.)
	A082-91378-C000	LIGHTS MTG. P.C. ASSY. W/LAMP BASES
4	0873-00901-0000	TRIGGER
	A873-00006-0000	CONTROL GRIP SWITCH ASSY.
	0020-00202-0000	SWITCH PLATE
	0017-00101-0528	#5-40 x 3/4 SLT. RND. HD. M.S. (2 REQ'D.)
	0873-00123-00XF	SWITCH & LIGHTS MTG. BRKT.
	0017-00101-0083	#4-20 x 3/8 PHIL. PAN HD. SCREW (2 REQ'D.)
5	0017-00101-0116	#10-32 x 3/8 HEX BUTTON HD. SCREW (5 REQ'D.)
	A873-00037-0000	1/8 TAMPER PROOF ALLEN KEY
6	A873-00031-0000	FOLLOWER & PLATE ASSY.
7	0873-00704-00XF	SLEEVE
8	A873-00025-0000	TUBING & PIVOT PIN PINNING ASSY.
9	0017-00101-0615	#8-32 x 3/8 SLT. PAN HD. M.S. (4 REQ'D.)
10	A873-00027-00XF	CENTERING BRKT. WELD ASSY.
11	0873-00910-0000	BUMPER
12	0873-00113-00XF	BUMPER MTG. BRKT.
13	0873-00909-0000	GROMMET - MODIFIED
14	0017-00101-0799	#10-32 x 3/8 SLT. HEX HD. SCREW (4 REQ'D.)
15	0017-00104-0034	FLAT WASHER
16	0017-00103-0082	7/16 - 14 NYLON INSERT LOCK NUT
17	0873-00701-00XF	ACTUATING PIN
18	0017-00100-0015	5/32 E-RING
19	0017-00042-0241	INSULATOR
20	0017-00101-0598	#8-32 x 5/16 SLT. HEX HD. SCR. (4 REQ'D.)
21	A873-00029-0000	SLIDE & MTG. BRKT. RIVET ASSY.
22	0017-00101-0691	#4-40 x 3/16 SLT. RND. HD. M.S. (4 REQ'D.)
23	0926-00100-00XF	FLAG SENSOR - RIGHT & LEFT
24	0926-00101-00XF	FLAG SENSOR - UP & DOWN
25	0017-00101-0553	#6-32 x 1/4 SLT. PAN HD. M.S. (8 REQ'D.)
26	0926-00700-00XF	P.C. MTG. POST (4 REQ'D.)
27	A082-91379-A000	CONTROL GRIP P.C. ASSY.
28	0873-00122-0000	P.C. SENSOR SHIELD
29	0017-00104-0004	#10 SPLIT LOCKWASHER (4 REQ'D.)
30	0017-00103-0081	#10-32 HEX NUT W/SEMS (4 REQ'D.)
		<b>NOT SHOWN LIST</b>
	0017-00101-0129	#10-32 x 1" CARRIAGE BOLT (4 REQ'D.)
	0017-00104-0025	#10 FLAT WASHER (4 REQ'D.)
	0017-00103-0011	#10-32 LOCKING NUT (4 REQ'D.)
		(ABOVE 3 ITEMS USED TO MOUNT
		CONTROL GRIP ASSY. TO CONTROL SHELF)
	0010-00266-0100	STRAIN RELIEF SPRING

**NO. 927 — GOLF COCKTAIL — PHOTOGRAPH**

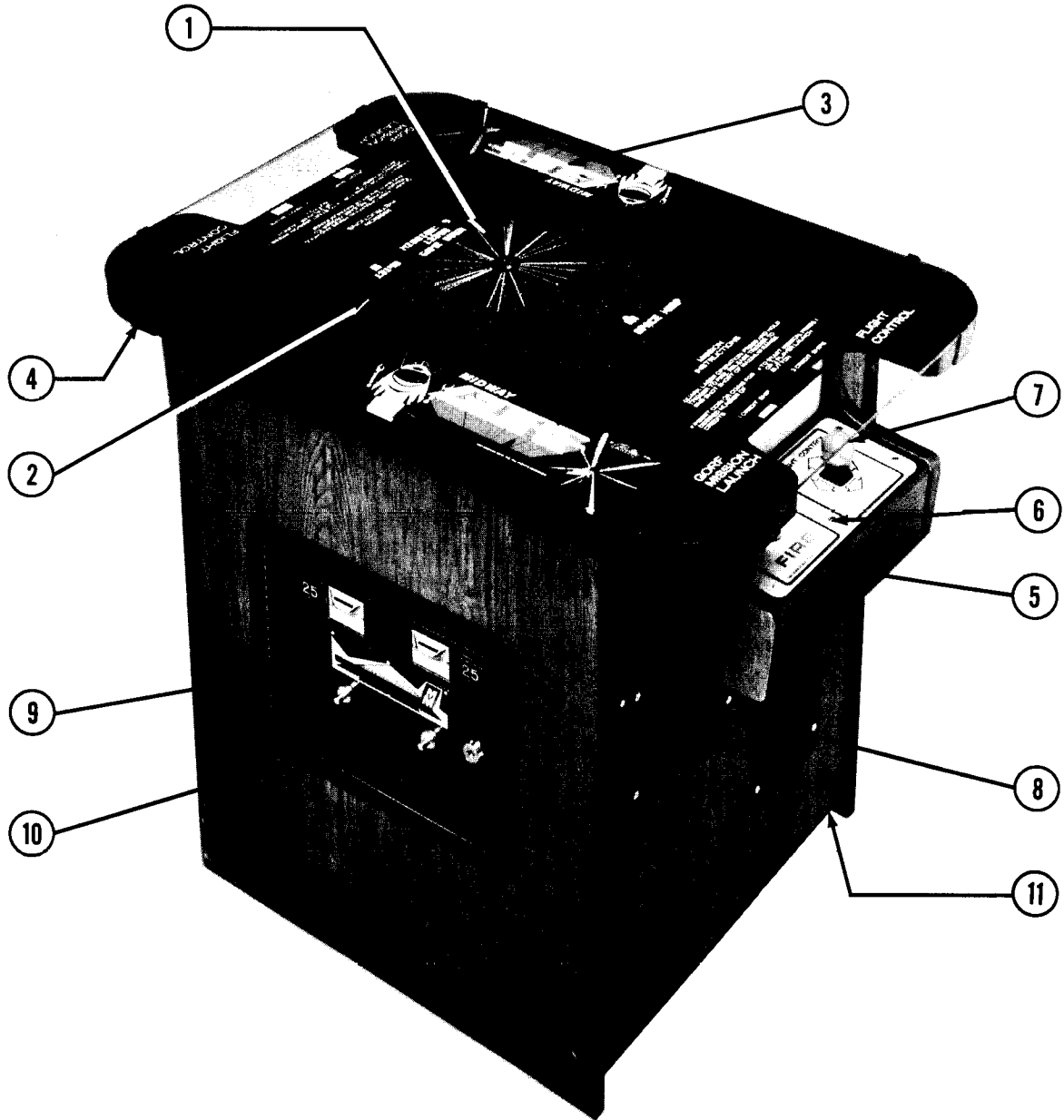

NO. 927 — GORF COCKTAIL — PHOTOGRAPH  
**ORDER BY PART NUMBER ONLY**

ITEM	PART NO	DESCRIPTION
1	0017-00003-0339	19" COLOR DUAL SYNC HORIZ. MTG. MONITOR - ELECTROHOME
		(OR)
1	0017-00003-0354	19" COLOR DUAL SYNC HORIZ. MTG. MONITOR - WELLS-GARDNER
2	A927-00022-0000	T.V. BEZEL & PLEXI ASSY.
	0869-00907-0000	PLEXI
	0927-00903-0000	T.V. BEZEL
3	0927-00900-00XF	GLASS TOP
4	0775-00104-00XF	GLASS CLIPS (8 REQ'D.)
	0017-00101-0117	#8 x 5/8 PHIL. TRS. HD. S.M.S. (16 REQ'D.)
5	0927-00109-00XF	CONTROL PANEL (2 REQ'D.)
6	0927-00905-0000	CONTROL PANEL OVERLAY - PLAYER #1
	0927-00906-0000	CONTROL PANEL OVERLAY - PLAYER #2 (OPPOSITE SIDE)
	0017-00101-0620	#8-32 x 1/2 CARRIAGE BOLT (8 REQ'D.)
	0017-00104-0022	#8 FLAT WASHER (8 REQ'D.)
	0017-00103-0061	#8-32 HEX NUT W/SEMS (8 REQ'D.)
	0017-00101-0341	#6 x 1/4 PHIL. TRS. HD. M.S. (4 REQ'D.)
7	0927-00014-0000	CONTROL ASSY. (2 REQ'D.)
8	0017-00009-0482	SPEAKER — VENT GRILLS (3 REQ'D.)
	0017-00003-0259	6" x 9" SPEAKER 8 OHM, 7W.
	0017-00009-0393	SPEAKER GRILL (SMALL) NOT SHOWN
	0017-00003-0161	4" SQ. SPEAKER 8 OHM, 7W. - NOT SHOWN
9	A090-00300-05BK	COIN DOOR ASSEMBLY
	0017-00003-0102	COIN METER
10	0090-00002-02BK	COIN DOOR FRAME
	0017-00101-0121	#6-32 x 5/16 PHIL. TRUSS HD. M.S. (3 REQ'D.) (MOUNTS COIN DOOR TO FRAME)
11	0017-00102-0048	LEG LEVELERS (4 REQ'D.)
	0017-00103-0026	LEG LEVELER NUTS (4 REQ'D.)
		<b><u>NOT SHOWN LIST</u></b>
	0017-00009-0033	BASSICK CLAMP (2 REQ'D.)
	0017-00101-0026	#8 x 5/8 HEX HD. M.S. (4 REQ'D.)
	0610-00132-0000	STRIKE (2 REQ'D.)
	0017-00101-0028	#8 x 3/4 HEX HD. S.M.S. (4 REQ'D.)

**NO. 927 — GORF COCKTAIL — INTERIOR ACCESS PICTURE**

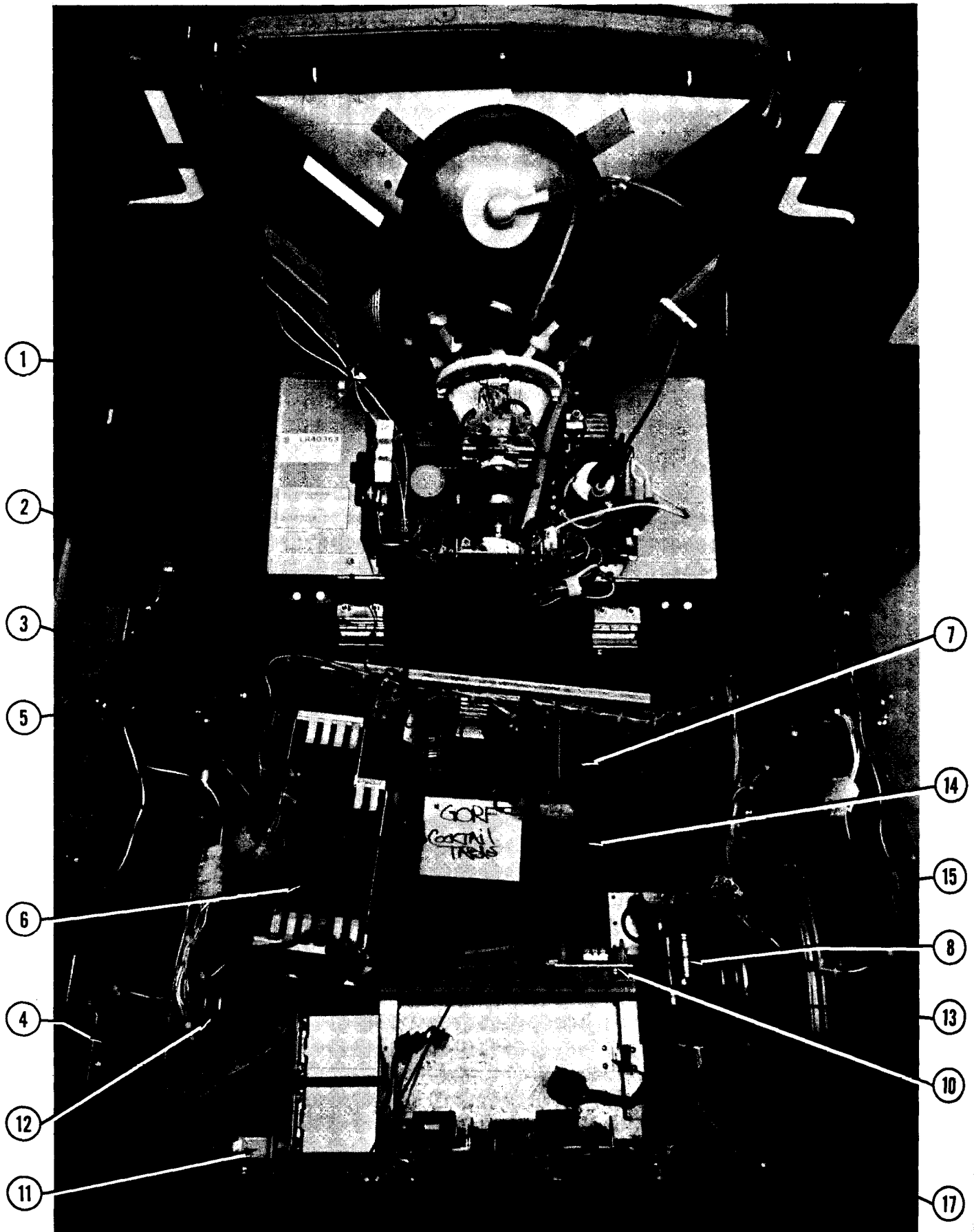

NO. 927 — GORF COCKTAIL — INTERIOR ACCESS PICTURE

*ORDER BY PART NUMBER ONLY*

ITEM	PART NO	DESCRIPTION
1	0017-00003-0339	19" COLOR MONITOR & CHASSIS — ELECTROHOME (OR)
1	0017-00003-0354	19" COLOR MONITOR & CHASSIS—WELLS-GARDNER
	A869-00007-00XF	MONITOR SUPPORT ASSY. - L.H.
	A869-00007-01XF	MONITOR SUPPORT ASSY. - R.H.
2	0017-00009-0495	2" HINGE (2 REQ'D.)
3	0927-00904-0000	LIGHT SHIELD (2 REQ'D.)
4	0927-00111-0000	RETAINING BRKT. (4 REQ'D.)
5	0017-00031-0044	LAMP SOCKET (4 REQ'D.)
	0017-00003-0219	#194 LAMP 14V., .27A. (4 REQ'D.)
6	A789-00002-0000	CARD RACK ASSY.
7	A927-00007-0000	TRANSFORMER BRD. ASSY.
8	A082-90411-A000	POWER SUPPLY P.C. ASSY.
	0624-00902-0100	P.C. SUPPORT BRKT. - 12" (3 REQ'D.)
	0624-00902-0300	P.C. SUPPORT BRKT. - 2-1/2"
9	A082-91363-A000	R-G-B INTERFACE P.C. BRD. ASSY.
10	A873-00023-0000	STEREO AUDIO AMP BRD. & BRKT. ASSY.
11	0017-00032-0071	INTERLOCK SWITCH
12	0017-00003-0161	4" SQ. SPEAKER 8 OHM, 7W.
13	0017-00003-0259	6" x 9" SPEAKER 8 OHM, 7W.
14	0017-00003-0222	FAN
	0775-00110-00XF	FAN PLATE
	0749-00106-00XF	VENT SCREEN
	0017-00101-0347	#6-32 x 1/2 R.H.M.S. (4 REQ'D.)
	0017-00104-0009	#6 EXT. WASHER (4 REQ'D.)
	0017-00103-0005	#6-32 HEX NUT (4 REQ'D.)
	0017-00101-0026	#8 x 5/8 SLT. HEX HD. M.S. (4 REQ'D.)
15	A927-00008-0000	ON-OFF SWITCH ASSY.
16	A090-00300-05BK	COIN DOOR ASSY.
17	A927-00019-0000	COIN BOX ASSY.
	A927-00020-0000	COIN BOX COVER ASSY.
	A625-00024-0000	COIN BOX GUIDE BRKT. ASSY.
	0625-00117-0000	COIN BOX GUIDE
		<u>ADDITIONAL PARTS LIST</u>
	A082-90508-A000	DRIVER P.C. BRD. ASSY.
	A082-90903-A000	AUDIO AMP BRD. ASSY.
	A889-00017-0000	LATCH SLIDE ASSY. (TABLE TOP PROP SUPPORT)
	G927-00005-0000	LEG KIT ASSY. (HIGH BASE) - OPTIONAL (INCLUDES 4 LEGS & HARDWARE)

**NO. 927 — GORF COCKTAIL TABLE — CONTROL SHELF ASSEMBLY**

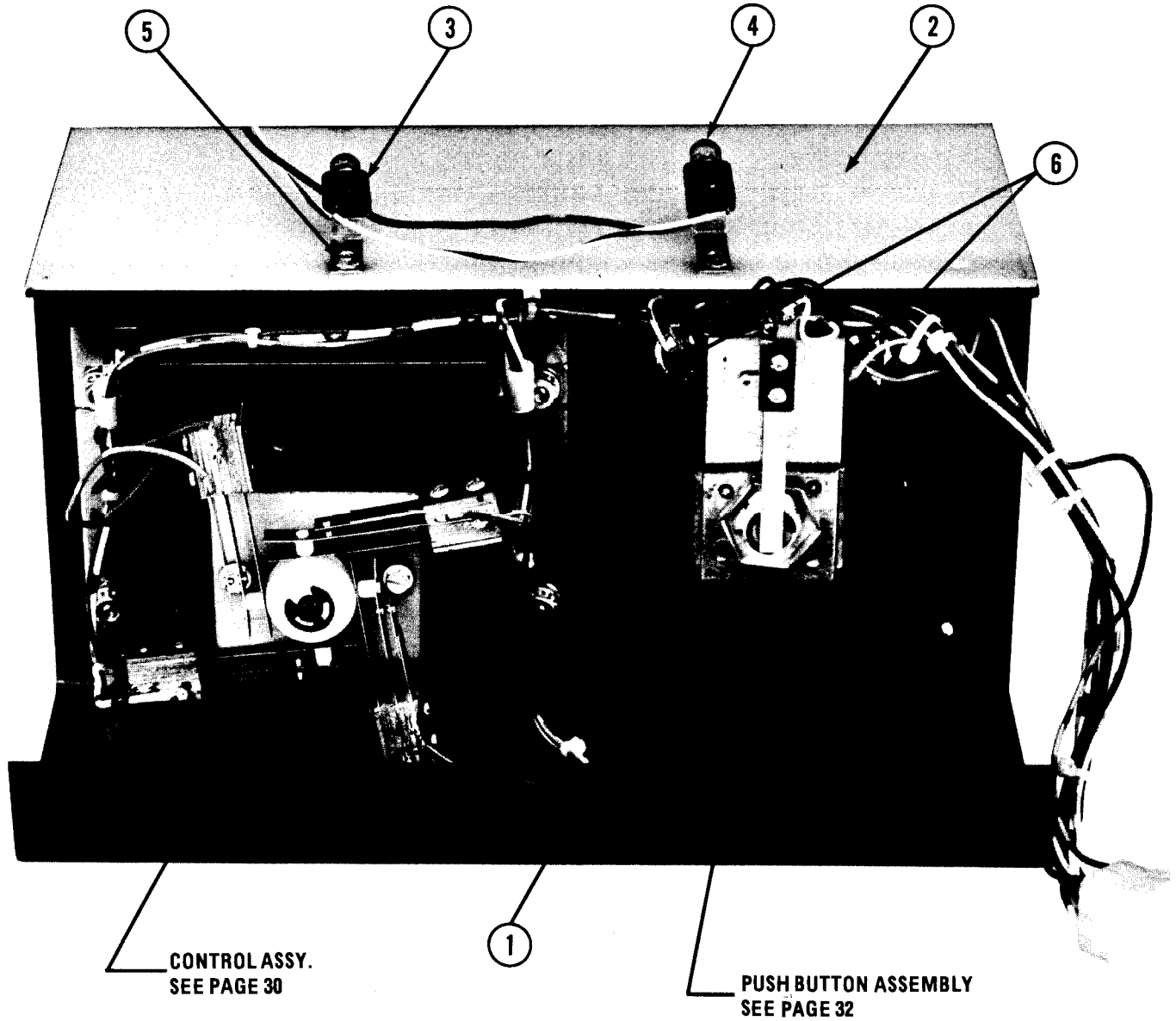

CONTROL ASSY.  
SEE PAGE 30

PUSH BUTTON ASSEMBLY  
SEE PAGE 32

NO. 927 — GOLF COCKTAIL TABLE — CONTROL SHELF ASSEMBLY

*ORDER BY PART NUMBER ONLY*

ITEM	PART NO	DESCRIPTION
1	0927-00109-00XF	CONTROL PANEL
2	0927-00904-0000	LIGHT SHIELD
3	0017-00031-0044	SOCKET - LAMP WEDGE (2 REQ'D.)
4	0017-00003-0219	LAMP #194 14V, .27A. WEDGE (2 REQ'D.)
5	0017-00101-0555	#6-32 x 5/16 SLT. HEX HD. SCREW (2 REQ'D.)
6	0017-00032-0051	SWITCH BUTTON - RED (2 REQ'D.)
		(PLAYER #1 ONLY)
		<u>NOT SHOWN LIST</u>
	0927-00110-00XF	SHELF BOTTOM (2 REQ'D.)
	0927-00111-0000	RETAINING BRKT. (4 REQ'D.)
		(MOUNTS SHELF TO CABINET)

# NO. 927 — GOLF COCKTAIL — CONTROL ASSEMBLY

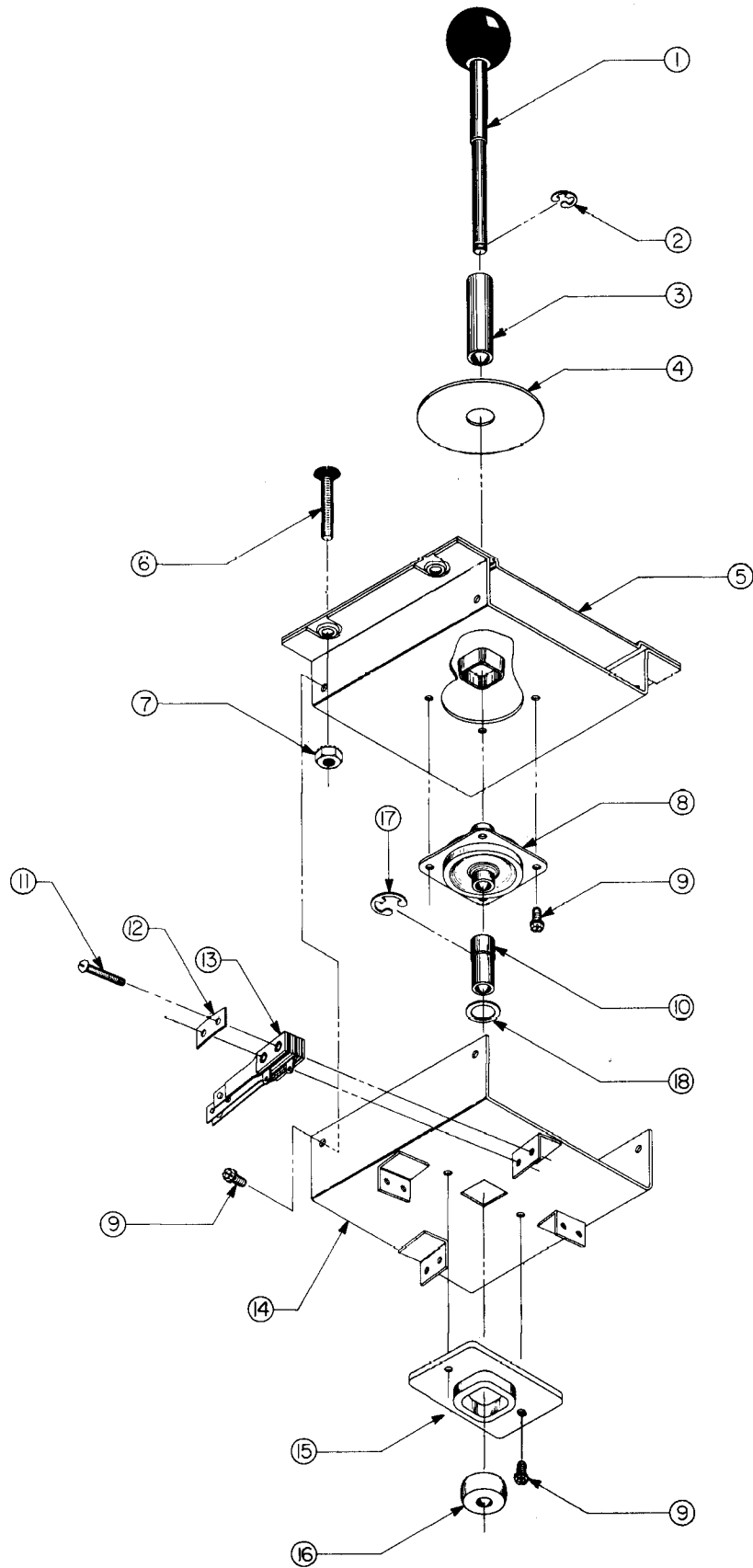



**NO. 927 — GOLF COCKTAIL — CONTROL ASSEMBLY**  
**ORDER BY PART NUMBER ONLY**

ITEM	PART NO	DESCRIPTION
1	A932-00022-0000	BALL & SHAFT ASSEMBLY
2	0017-00100-0025	1/4" E-RING
3	0921-00702-0000	STOP SPACER
4	0921-00902-0000	SLIDE PLATE
5	A921-00008-00XF	SPOT WELD ASSY.
6	0017-00101-0713	#8-32 x 1" SLT. FLAT HD. SCREW (4 REQ'D.)
7	0017-00103-0061	#8-32 HEX NUT W/SEMS (4 REQ'D.)
8	0932-00902-0000	GROMMET
9	0017-00101-0598	#8-32 x 5/16 SLT. HEX HD. M.S. (10 REQ'D.)
10	0921-00701-0000	SLEEVE
11	0017-00101-0527	#5-40 x 5/8 SLT. RND. HD. SCR. (8 REQ'D.)
12	0020-00202-0000	SWITCH PLATE (4 REQ'D.)
13	A932-00009-0000	SWITCH ASSEMBLY (4 REQ'D.)
14	A921-00009-0000	STOP PLATE & SWITCH BRKT. ASSY.
15	0927-00908-0000	WEAR PLATE
16	0921-00700-0000	ACTUATOR
17	0017-00100-0115	7/16" E-RING
18	0017-00104-0111	FLAT WASHER

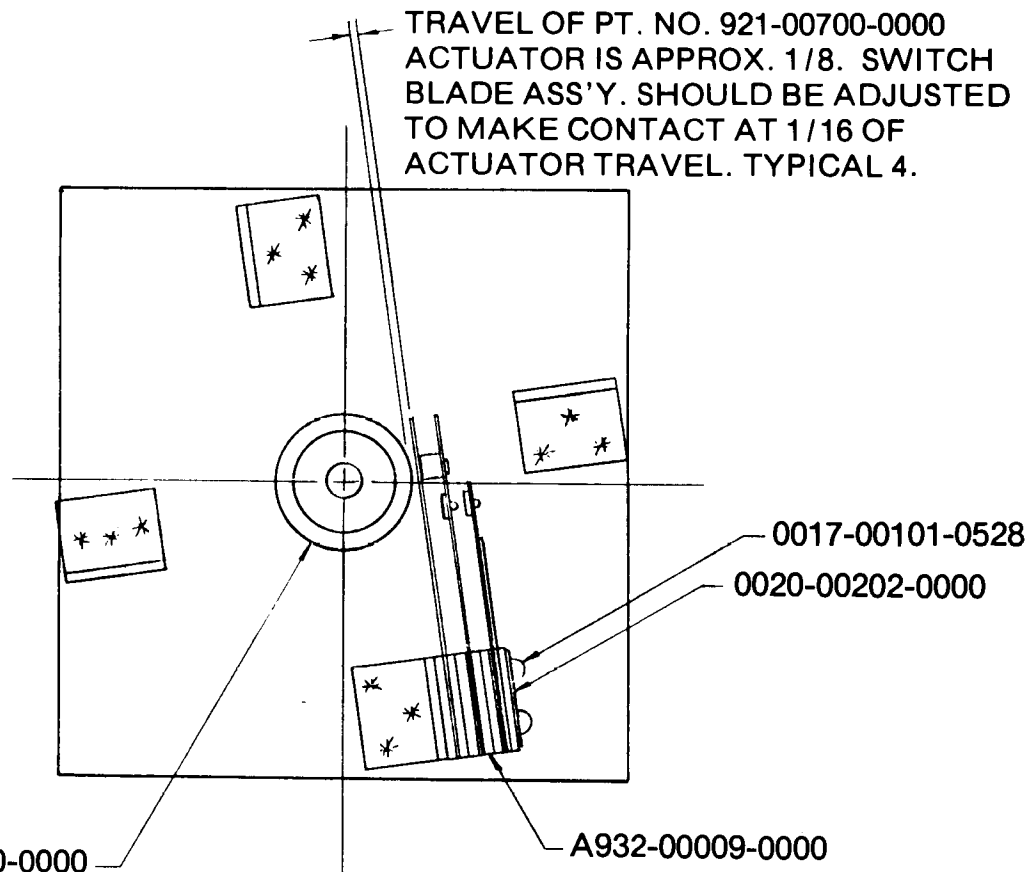

**NO. 927 — GOLF COCKTAIL TABLE — PUSH BUTTON ASSEMBLY**

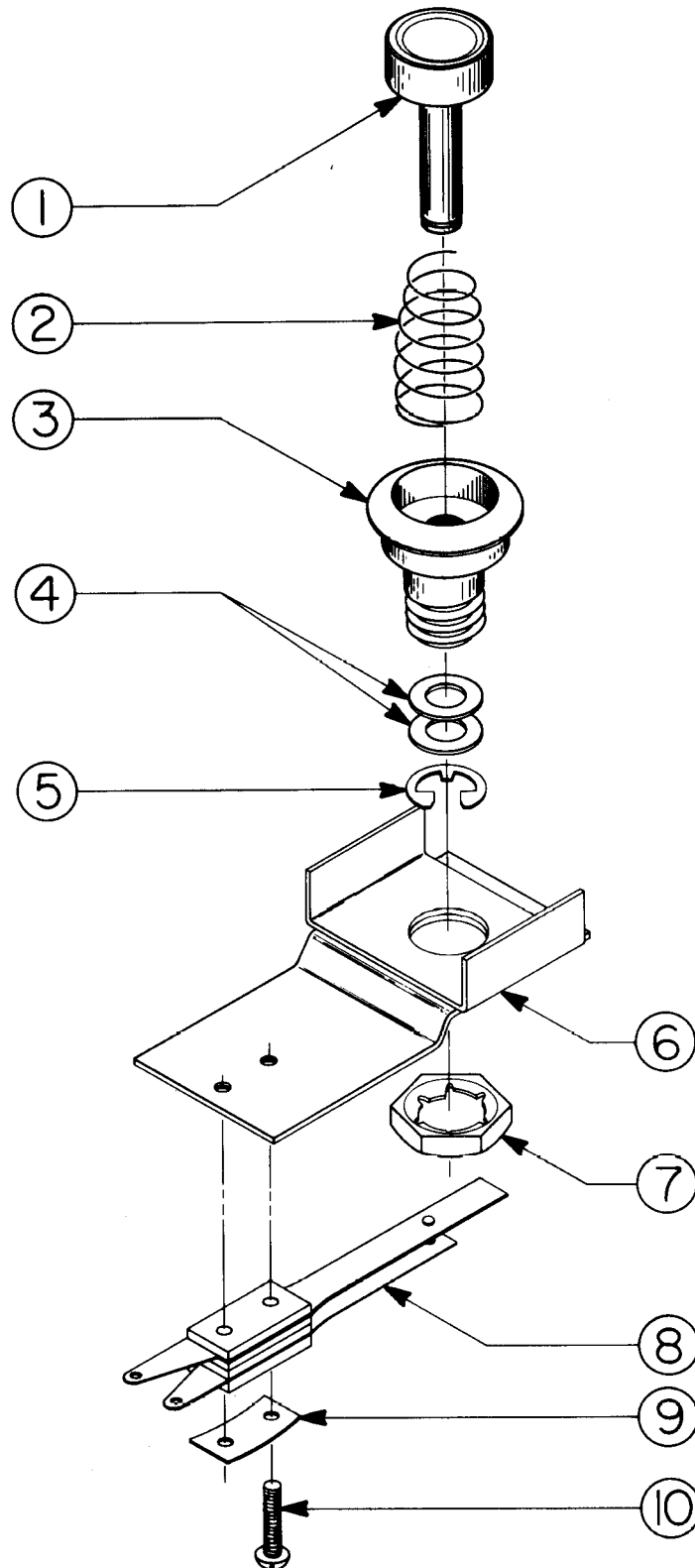

NO. 927 — GORF COCKTAIL TABLE — PUSH BUTTON ASSEMBLY

*ORDER BY PART NUMBER ONLY*

ITEM	PART NO	DESCRIPTION
1	0017-00009-B384	BUTTON - RED
2	0010-00593-0000	SPRING
3	0017-00009-0376	BUTTON HOUSING
4	0017-00104-0028	FLAT WASHER (2 REQ'D.)
5	0017-00100-0025	1/4" E-RING
6	A855-00016-0000	PUSH BUTTON ASSY. (FIRST 5 ITEMS)
7	A927-00011-0000	MOUNTING BRKT. ASSY.
8	0017-00103-0054	PAL NUT
9	A739-00016-0000	SWITCH ASSEMBLY
10	0020-00202-0000	SWITCH PLATE
	0017-00101-0526	#5-40 x 9/16 PHIL. HD. M.S. (2 REQ'D.)

**NO. 873 & 926 & 927 GORF UPRIGHT, MINI & COCKTAIL—FRONT DOOR ASSY.**

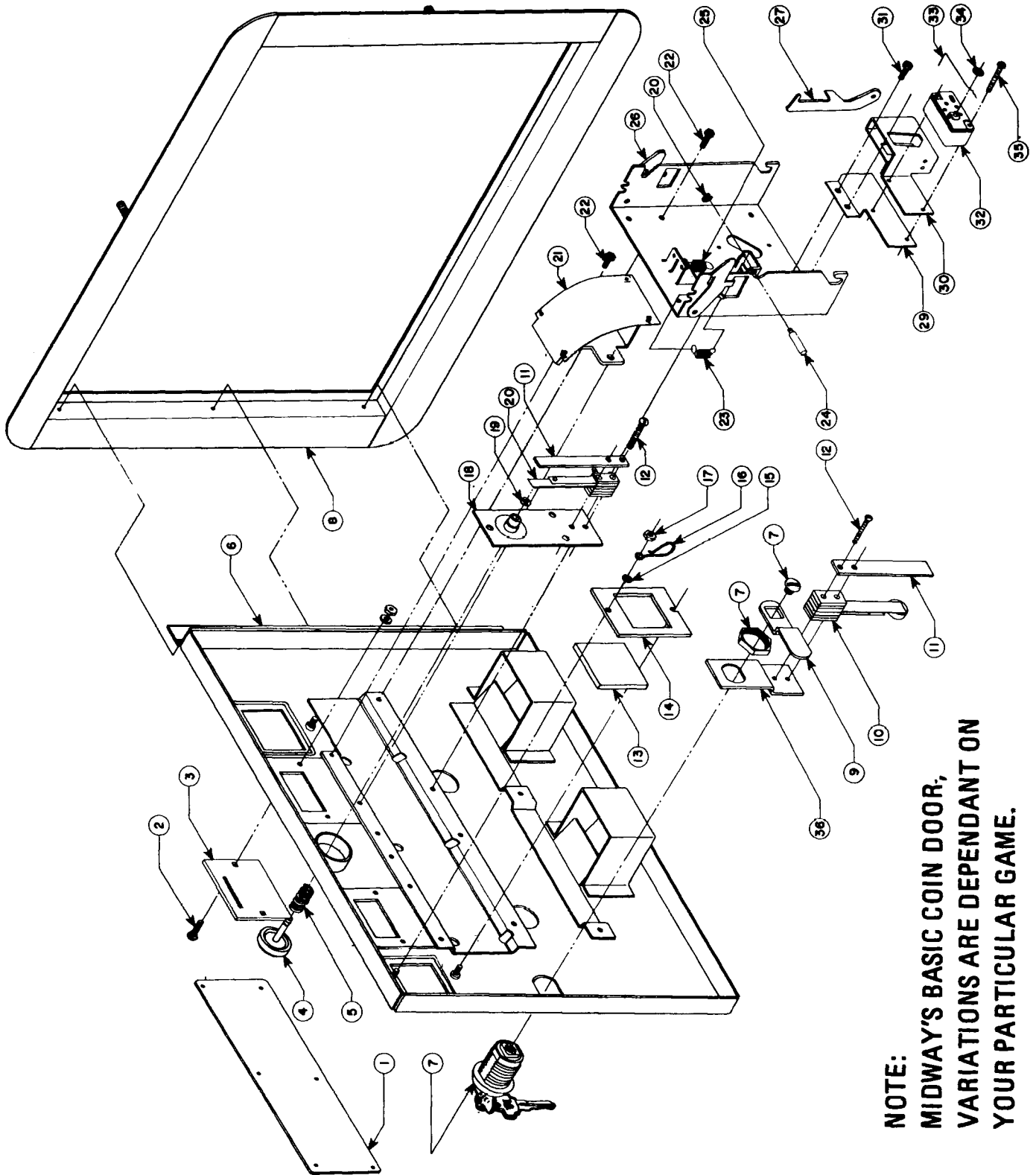

**NOTE:  
MIDWAY'S BASIC COIN DOOR,  
VARIATIONS ARE DEPENDANT ON  
YOUR PARTICULAR GAME.**

NO. 873 & 926 & 927 GORF UPRIGHT, MINI & COCKTAIL—FRONT DOOR ASSY.

*ORDER BY PART NUMBER ONLY*

ITEM	PART N <sup>o</sup>	DESCRIPTION
1	0090-00902-0000	DRESS PLATE
	0090-00902-0100	DRESS PLATE W/O BUTTON TO START GAME
2	0017-00101-0552	#6-32-x 1/4 CARRIAGE BOLT (2)
3	0090-00117-03XF	COIN ENTRY PLATE (25¢)
4	0090-00906-0000	PLASTIC START BUTTON
5	0010-00007-0000	COMPRESSION SPRING
6	A090-00020-2003	DOOR ASSY. DOUBLE ENTRY
7	0017-00005-0050	DOOR LOCK & KEY WITH SCREW & NUT
8	0090-00002-02BK	DOUBLE DOOR FRAME
9	0017-00005-0041	421 N.S. CAM
10	0090-00901-0000	DOOR SWITCH
	0090-00126-01XF	SWITCH BACKUP PLATE
12	0017-00101-0528	#5-40 x 3/4" LNG. M.S.
13	0090-00903-9500	25¢ WINDOW
14	0090-00143-0000	COIN PLEX RETAINER
15	0017-00104-0002	SPLIT LOCK WASHER
16	0017-00007-0019	KEY HOOK
17	0017-00103-0087	#6-32 HEX NUT
18	0090-00010-0000	SW. PLATE & OILLITE ASSY.
19	0017-00100-0018	"E" RING
20	0090-00131-0000	SWITCH
21	0090-00104-0000	TOP & BTM. COIN CHUTE W/BRKT. ASSY.
22	0017-00101-0123	#8 x 1/4 SCREW
23	0010-00181-0100	SPRING
24	0090-00129-00XF	PIVOT POST
25	0010-00134-0000	SPRING
26	0090-00008-0000	ACCEPTOR FRAME ASSY.
27	0093-00155-00XF	REJECTOR LEVER
28	0017-00100-0012	"E" RING
29	0090-00162-00XF	COIN SWITCH MTG. BRKT. - SMALL
29	0090-00163-00XF	COIN SWITCH MTG. BRKT. - LARGE
30	0017-00005-0203	COIN SWITCH CHUTE - SMALL
30	0017-00005-0204	COIN SWITCH CHUTE - LARGE
31	0017-00101-0124	#6 x 1/4 SCREW
32	0017-00005-0195	COIN SWITCH
33	0010-00599-0000	COIN SWITCH WIRE
34	0017-00007-0132	PUSH-ON RING (BLK.)
35	0017-00101-0698	#4-40 x 3/4 SCREW (2 REQ'D.)
36	0090-00128-00XF	SWITCH BRKT. - DOOR TILT
	A090-00061-0000	ANTI-STRING DEVICE ASSY.
	A090-00064-0000	ANTI-PENNY DEVICE ASSY.

**NO. 873 & 926 & 927 GORF U.R., MINI & C.T.—COMMERCIAL CARD RACK ASSY.**

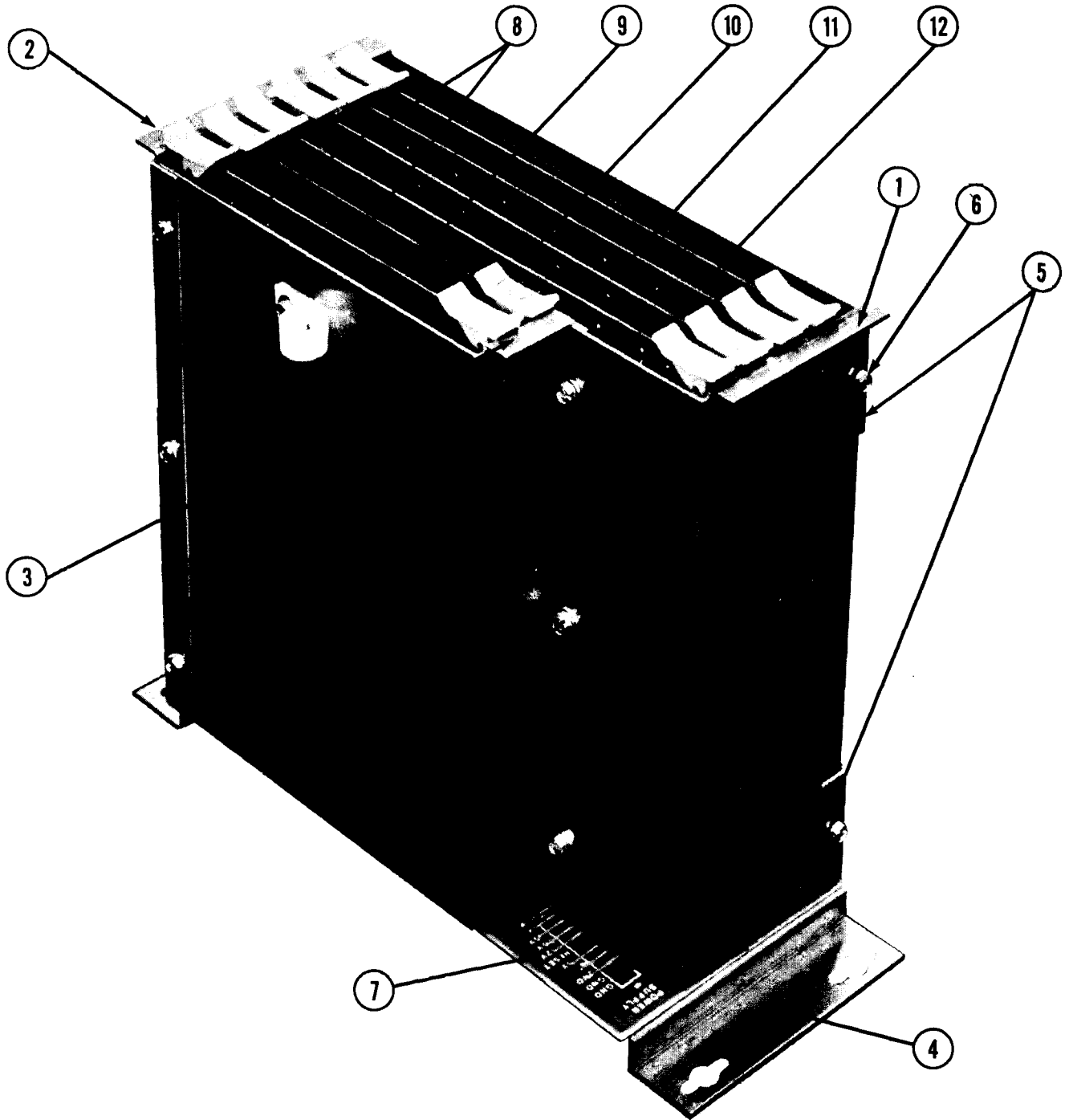

*ORDER BY PART NUMBER ONLY*

ITEM	PART N <sup>o</sup>	DESCRIPTION
1	A789-00003-0000	P.C. RACK ASSY. - RIGHT
2	A789-00004-0000	P.C. RACK ASSY. - LEFT
3	A789-00005-0000	P.C. RACK ASSY. - BASE
4	0789-00100-0000	MTG. BRKT. SUPPORT (2 REQ'D.)
5	0789-00106-0000	RACK STRAP (2 REQ'D.)
6	0017-00101-0099	#6 x 1/4 SLT. HEX HD. SCREW (11 REQ'D.)
	0017-00104-0019	#6 FLAT WASHER (3 REQ'D.)
7	A082-90006-B000	BACK PANEL P.C. ASSY. (MOTHER BOARD)
8	A082-91356-C000	RAM BOARD ASSY.
9	A082-91354-F000	CPU BOARD ASSY.
10	A082-91355-C000	PATTERN TRANSFER BOARD ASSY.
11	A084-91364-A873	PROGRAMMED ROM/RAM BOARD ASSY.
12	A084-90708-C873	GAME LOGIC BOARD ASSY.
	0017-00007-0153	P.C. BOARD SUPPORT (2 REQ'D.) (NOT SHOWN)

NO. 873 & 926 & 927 GORF U.R., MINI & COCKTAIL—TRANSFORMER BD. ASSY.

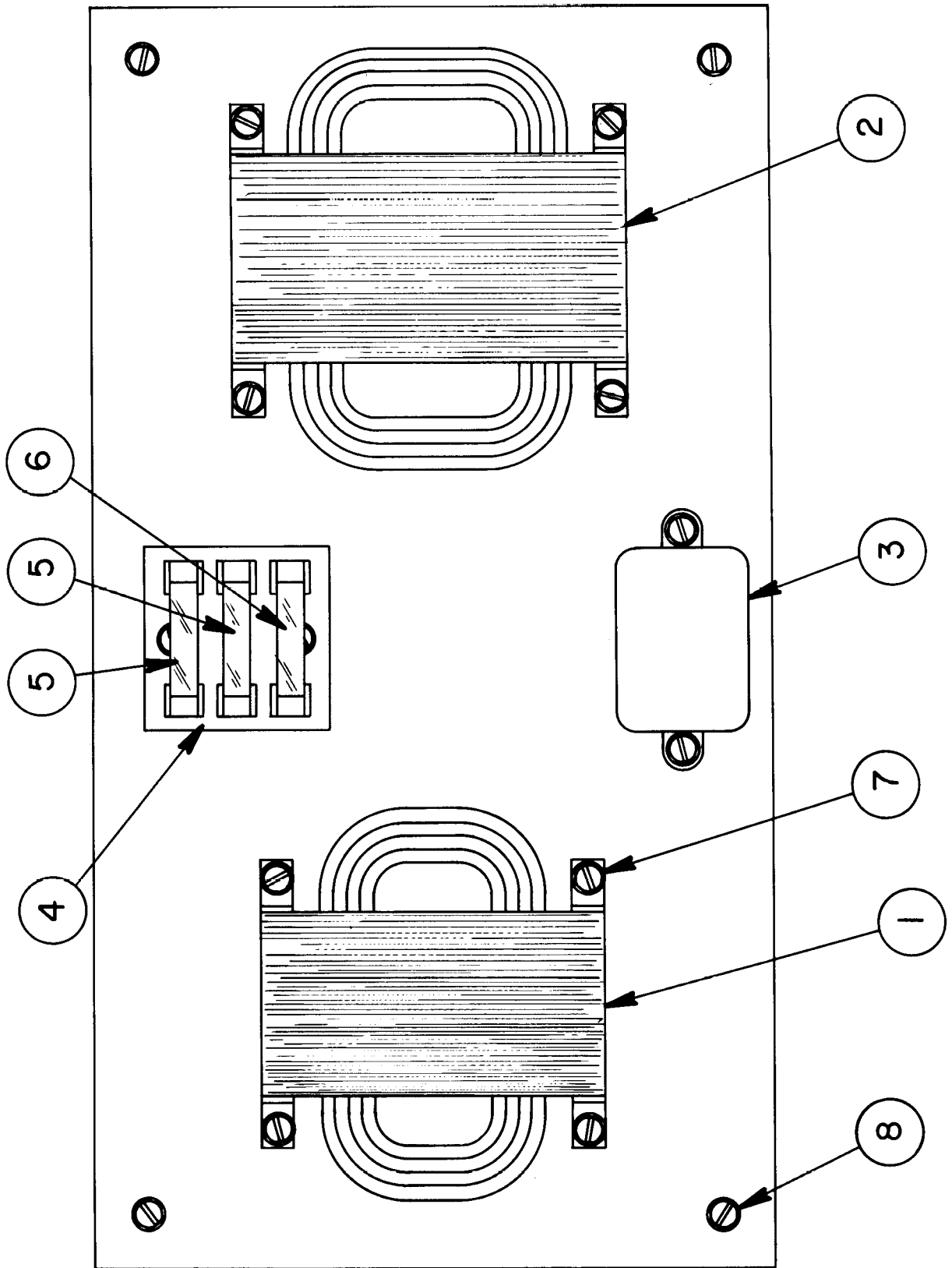



***ORDER BY PART NUMBER ONLY***

ITEM	PART NO	DESCRIPTION
1	MT00-00085-0000	TRANSFORMER 115V 50HZ (COCKTAIL)
1	MT00-00087-0000	TRANSFORMER 115V (UPRIGHT & MINI)
2	MT00-00091-0000	TRANSFORMER 115/220V (COCKTAIL)
2	MT00-00087-0000	TRANSFORMER 120/240V (UPRIGHT & MINI)
3	0017-00003-0114	NOISE FILTER
4	0720-00001-0300	3 POSITION FUSE CLIP
5	0017-00003-0004	FUSE 2A 250V SLO-BLO (2 REQ'D.)
6	0017-00003-0217	FUSE 2-1/2A 125V SLO-BLO
7	0017-00101-0015	#6 x 1/2 SLT HEX HD. SCREW (12 REQ'D.)
8	0017-00101-0031	#8 x 1 SLT. HEX HD. SCREW (4 REQ'D.)
	A866-00049-0000	LINE CORD ASSY. (NOT SHOWN)

# NOTES

---

This space is provided for personal notes

GORF U.R.  
 MIDWAY MFG CO.  
 10750 W. GRAND AVE.  
 FRANKLIN PARK, IL. 60131

WIRING SCHEMATIC \* M051-00873-A037

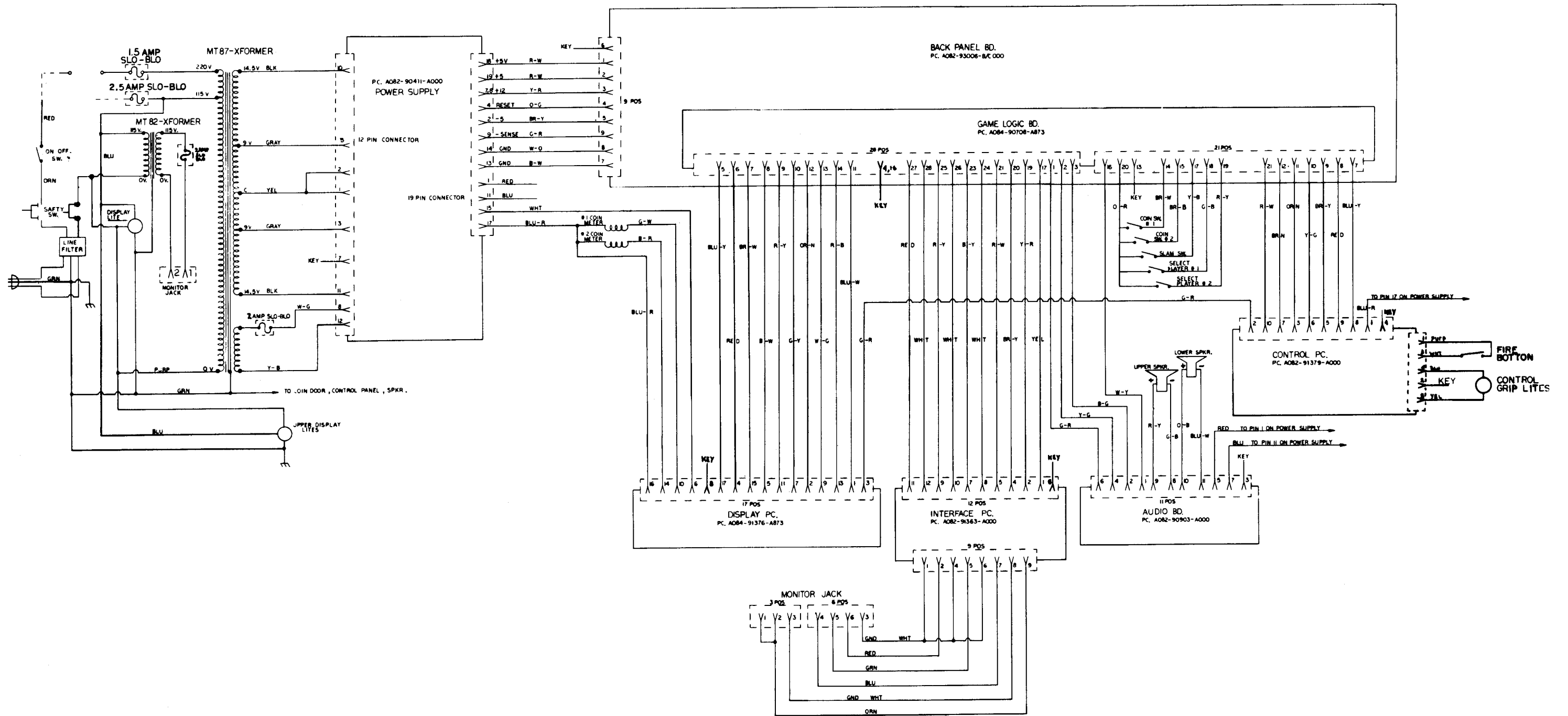

GOLF MINI  
MIDWAY MFG. CO.  
10750 W. GRAND AVE.  
FRANKLIN PARK, IL. 60131

WIRING SCHEMATIC \* MO51-00926-A025

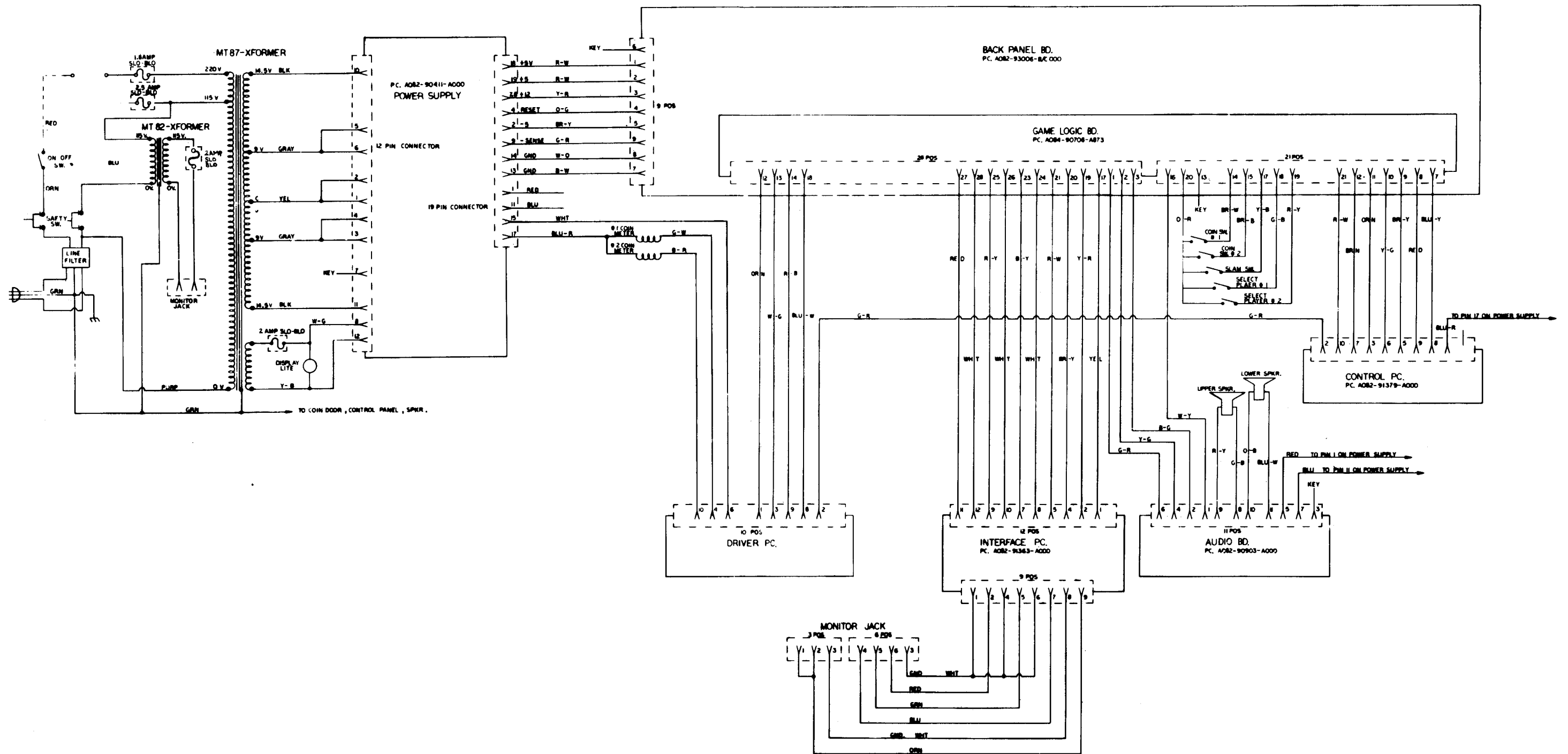

GORF C.T.  
 MIDWAY MFG. CO.  
 10750 W. GRAND AVE.  
 FRANKLIN PARK, IL. 60131

WIRING SCHEMATIC # MC51-00927-A023

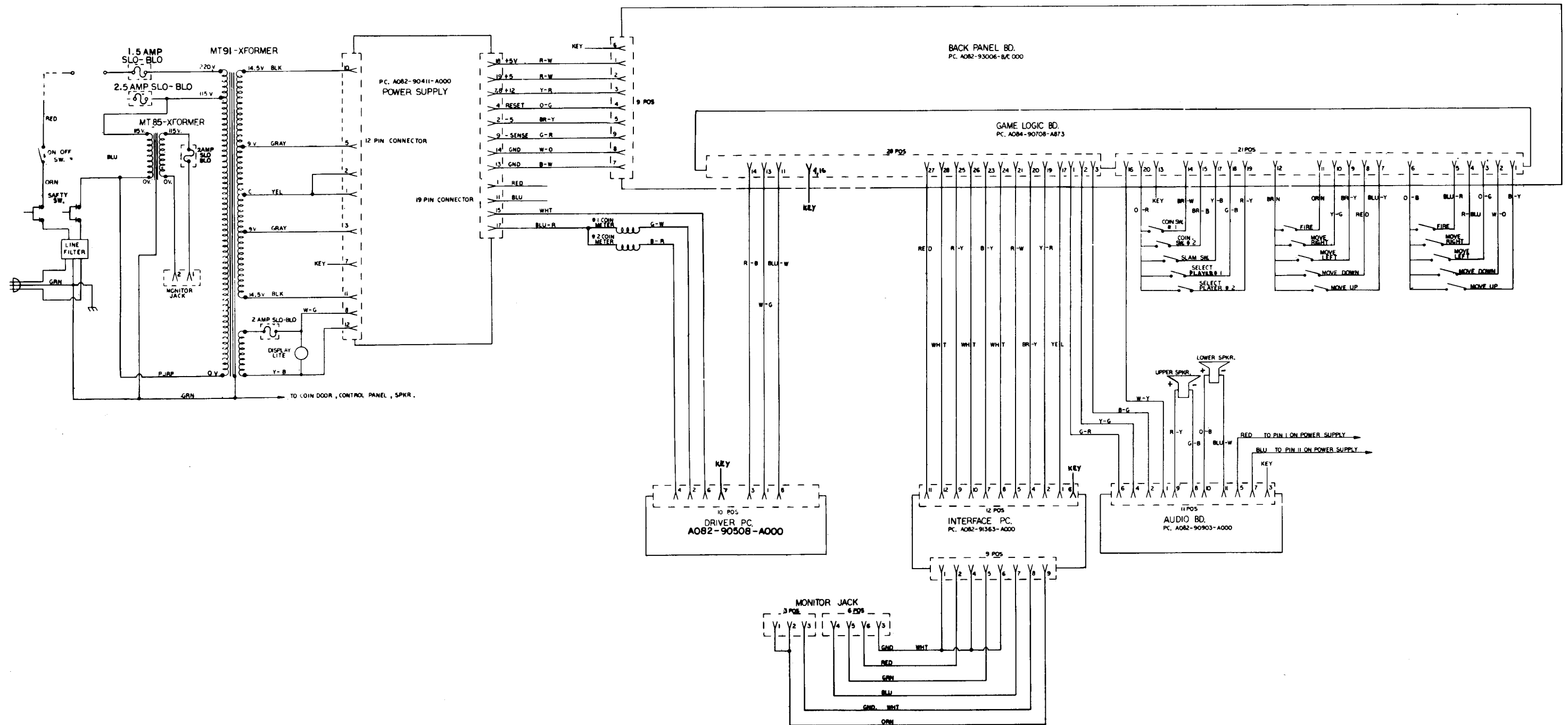

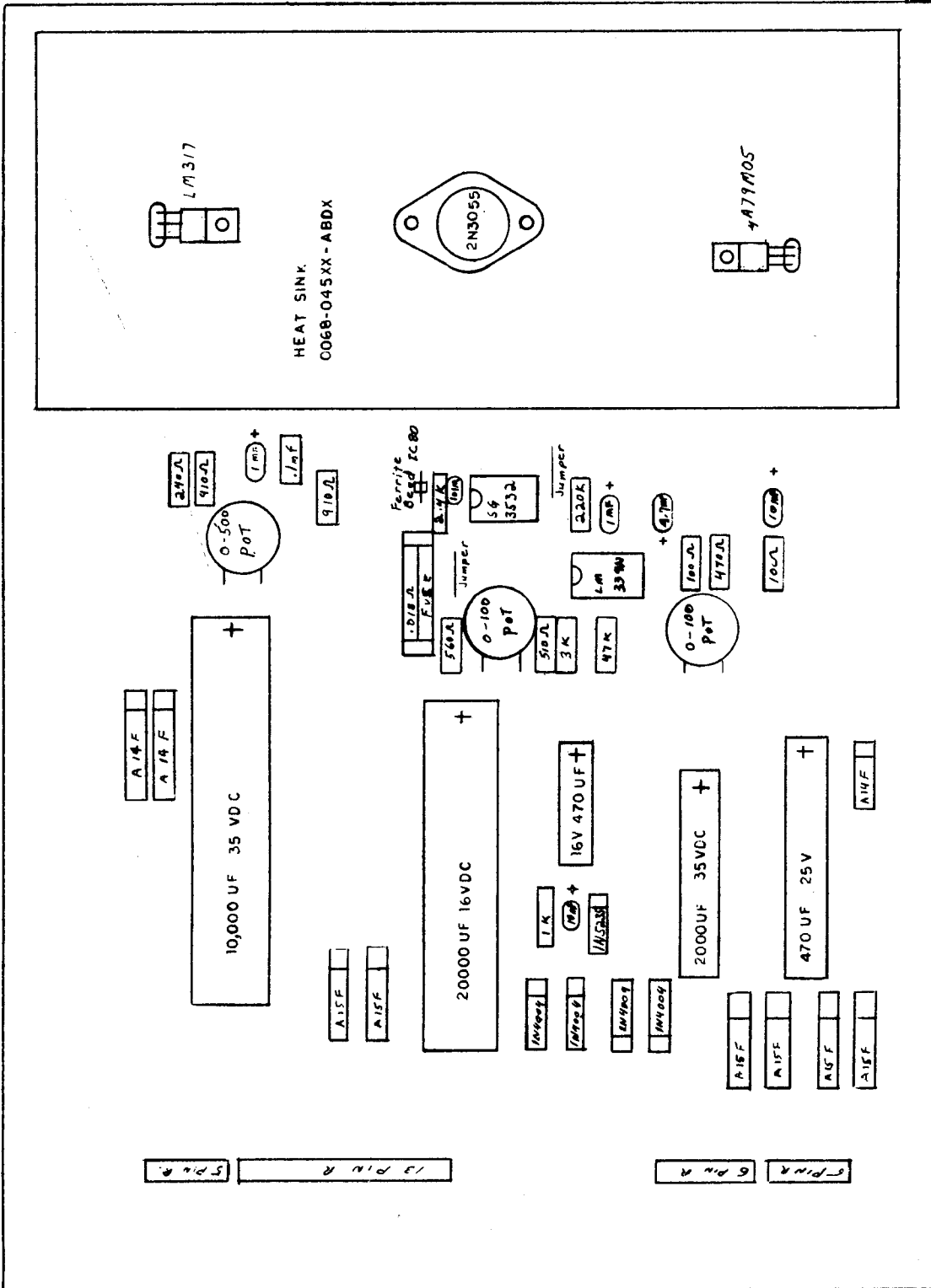

REVISIONS		USED ON		SCALE		HEAT TREAT		MATERIAL		FINISH	
MIDWAY MFG. CO.		NO. REQ'D 1									
FRANKLIN PK. ILL.											
PART NO.		POWER SUPPLY		DATE 11 25 80		DRN M.M.		CONCENTRICITY T.Y.R. .003		FRACTIONAL .1/64 CKD.	
A082-90411 - A000		ASSY B. DRWG.									

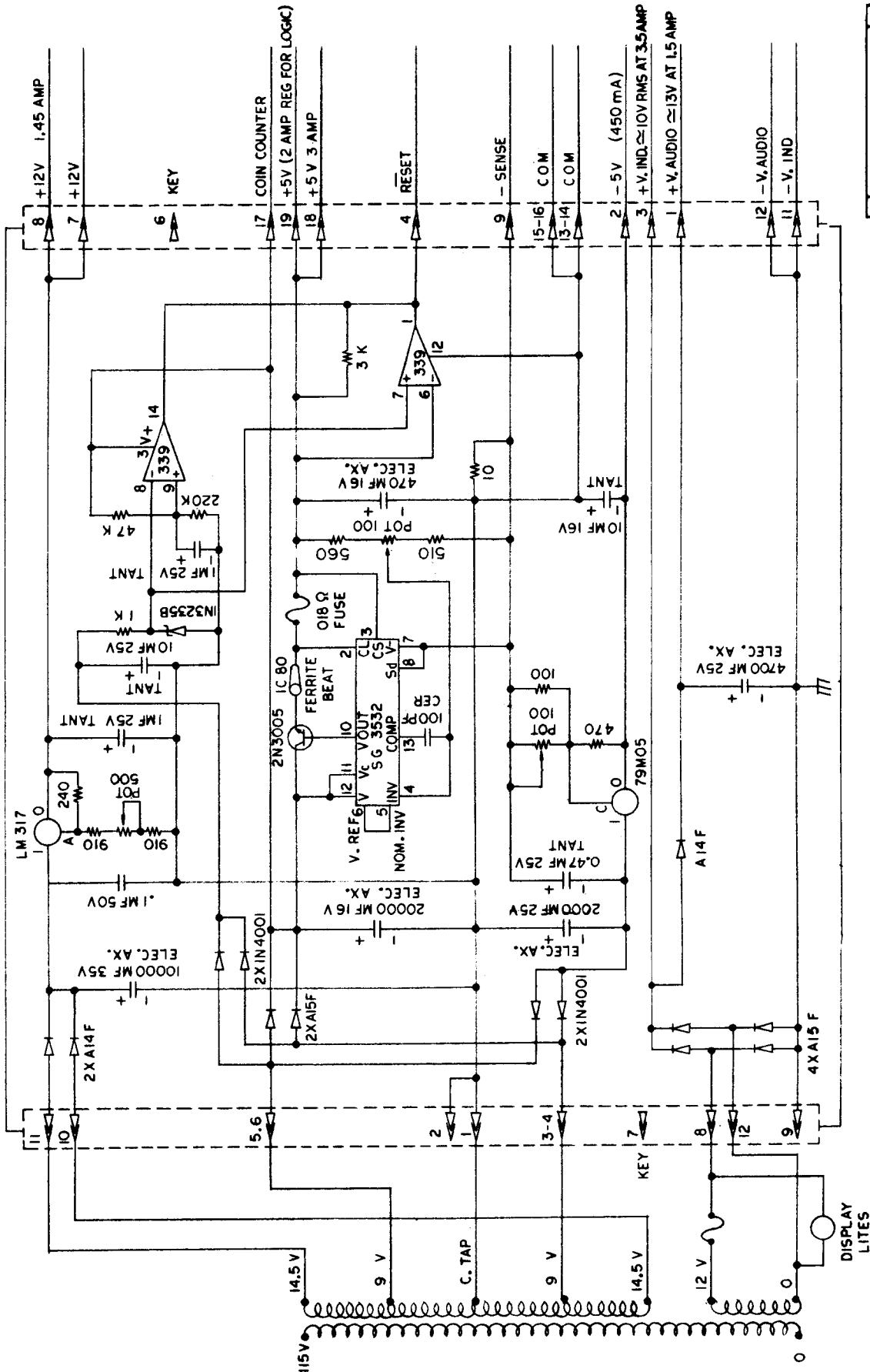

DRAWING NO. M051-00789-A011

REVISIONS		USED ON		SCALE		HEAT TREAT		MATERIAL		PART NO.	
										A082-90411-A000	
MIDWAY MFG. CO.				COMMERCIAL CARD RACK				PWR SPLY SCHEMATIC			
FRANKLIN PK. ILL.											
DO NOT SCALE DIMS.				UNLESS SPECIFIED				DATE 7/24/80			
DIM. TOLERANCES				CONCENTRICITY T.I.R. .003				CHECKED			
UNLESS SPECIFIED				.001				DRAWN			
.001				.001				.001			
.001				.001				.001			
.001				.001				.001			

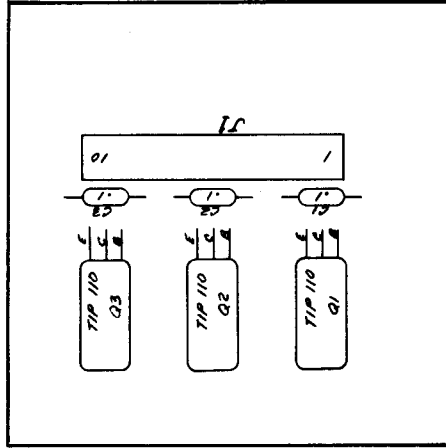

M051-0926-A023

SCALE	DATE	DRAWN BY	TITLE
2/1	9/29/87	JHT	MIDWAY MFG. CO.
MATERIAL	FINISH	FOR	FORM
			DRIVER 90.
			MINI & CACK TAIL
			NO
			A023 - 90508-0000
			Part Base # 10.8

DEBRA PRODUCTS CO. 1987



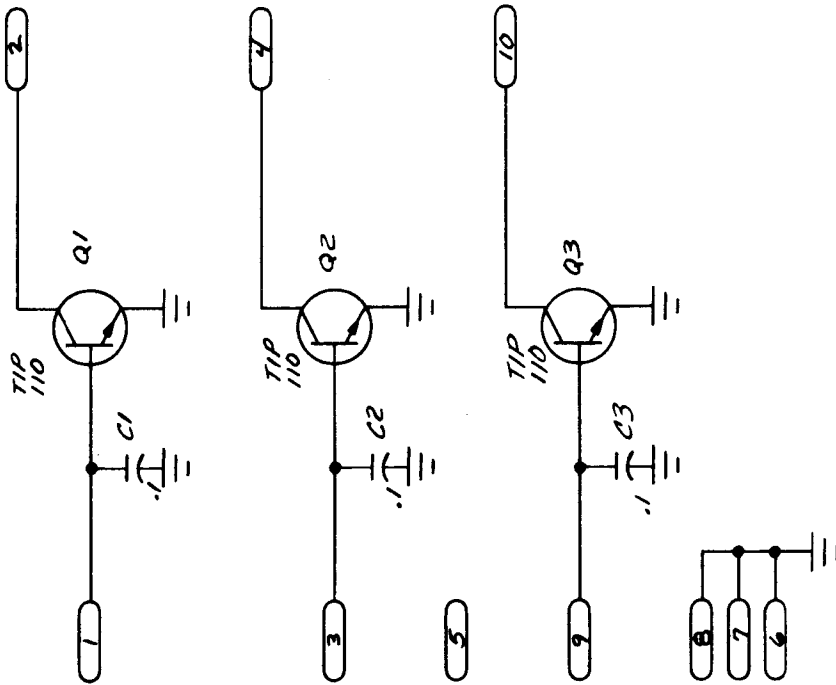

J1

M051-00926-A024

SCALE	DATE	DRAWN BY		
	9-17-80	OTTO	MIDWAY MFG. CO.	
MATERIAL	FINISH	TITLE DRIVER BOARD		
TOLERANCES		FOR		
X1: .01		GOLF MINI & COCKTAIL		
X10: .005		NO		
ANGULAR:		A082-90508-A000		
PROD RELEASE 10-10-88				

PART NO. \_\_\_\_\_

PART NO. \_\_\_\_\_

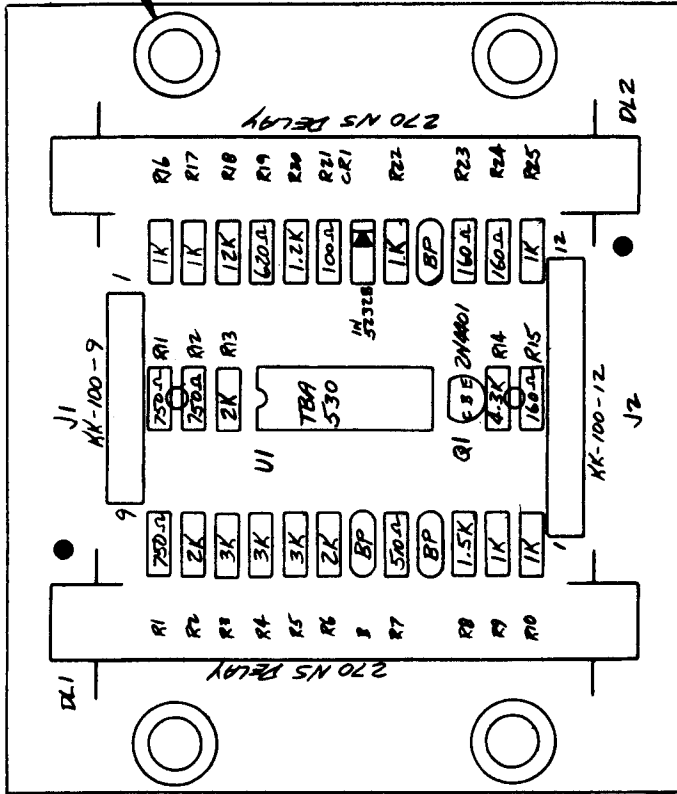

REV. AEC 1968

REVISES

**MIDWAY MFG. CO.**  
FRANKLIN PARK, ILL. 60131

PART NO. A082-91363-0000

**RGB INTERFACE COMM. CARD BACK**

M051-00873-A029

NO. NOT SCALE SWP. NO. RECD

USED ON

SCALE	MAT'L.
TREAT TREAT	FINISH
DATE	DATE

DIM. TOLERANCES  
CONCENTRICITY T.I.R. .005  
FRACTIONAL .5 1/64  
DECIMAL .5 .005  
HOLE DIA. .5 .005 - .005

TBA-530

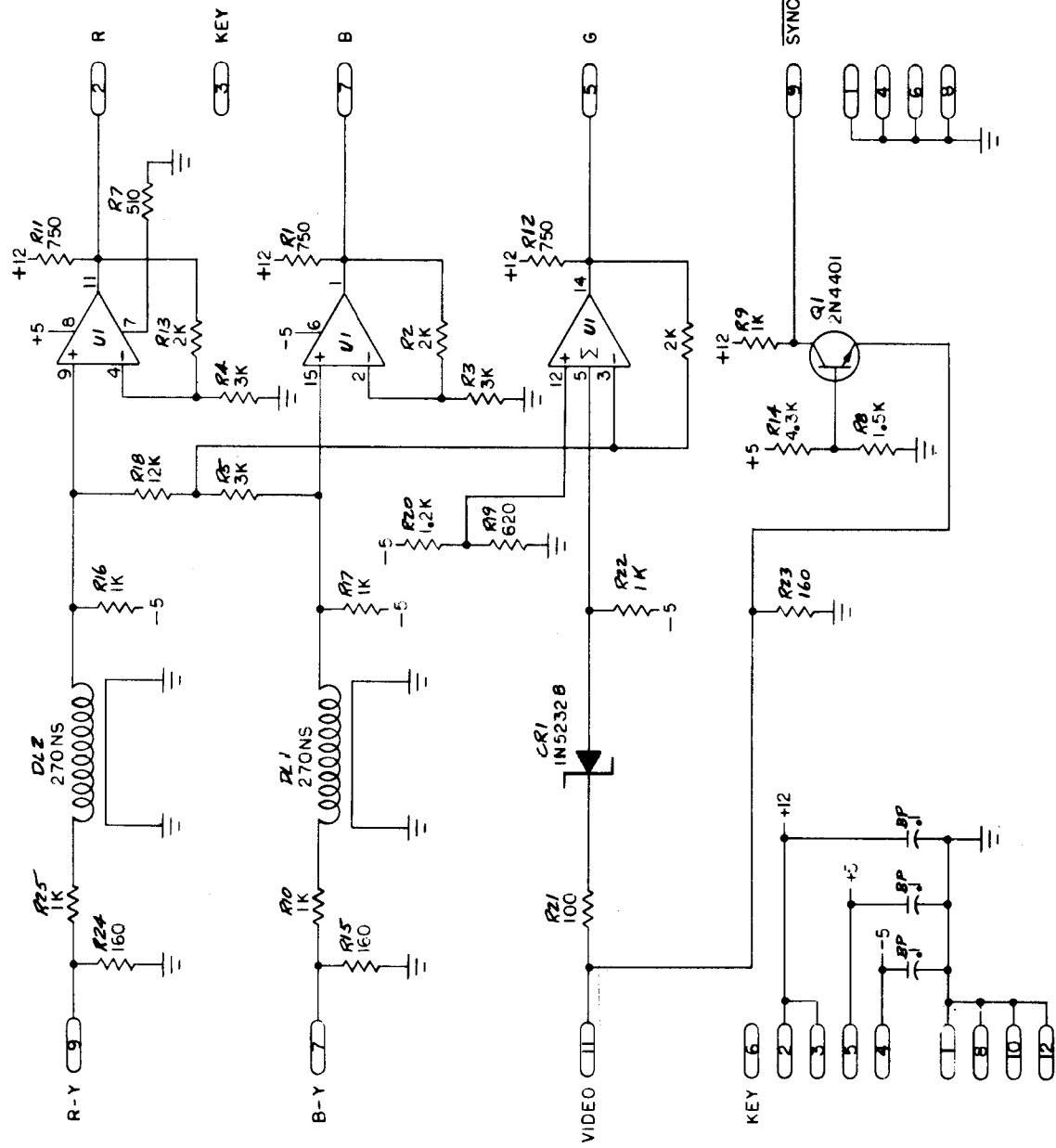

M051-00873-A030

SCALE	DATE	DRAWN BY	TITLE
NONE	8-29-60	OTTO	MIDWAY MFG. C.O.
MATERIAL			RGB INTERFACE
			FOR CCRS
			NO A082-91363-A000

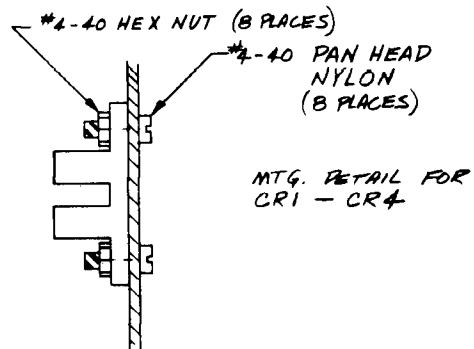
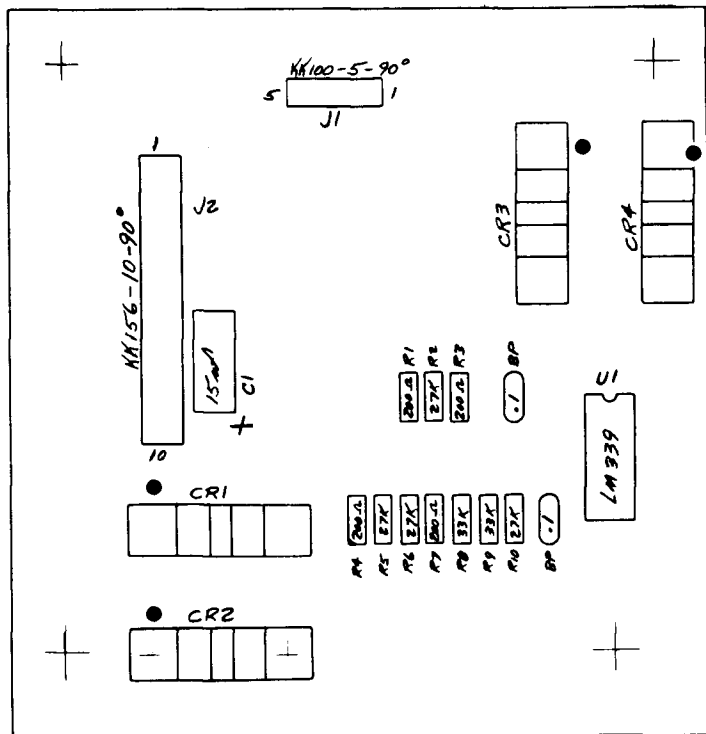

MTG. DETAIL FOR  
CR1 - CR4

M051-00873-A027

DO NOT SCALE DWG.		HEAT TREAT	SCALE 2-1	USED ON CCR-600F	NO. REQ'D 1	MIDWAY MFG. CO. FRANKLIN PK. ILL.
DIN. TOLERANCES UNLESS SPECIFIED		MAT'L.	CONTROL GRIP ASSY.		PART NO.	
CONCENTRICITY ± 0.05		FINISH				
FRACTURAL ± 0.001		DATE				
DECIMAL ± 0.001						
HOLE DIA. ± 0.001						

A082-91379-A000

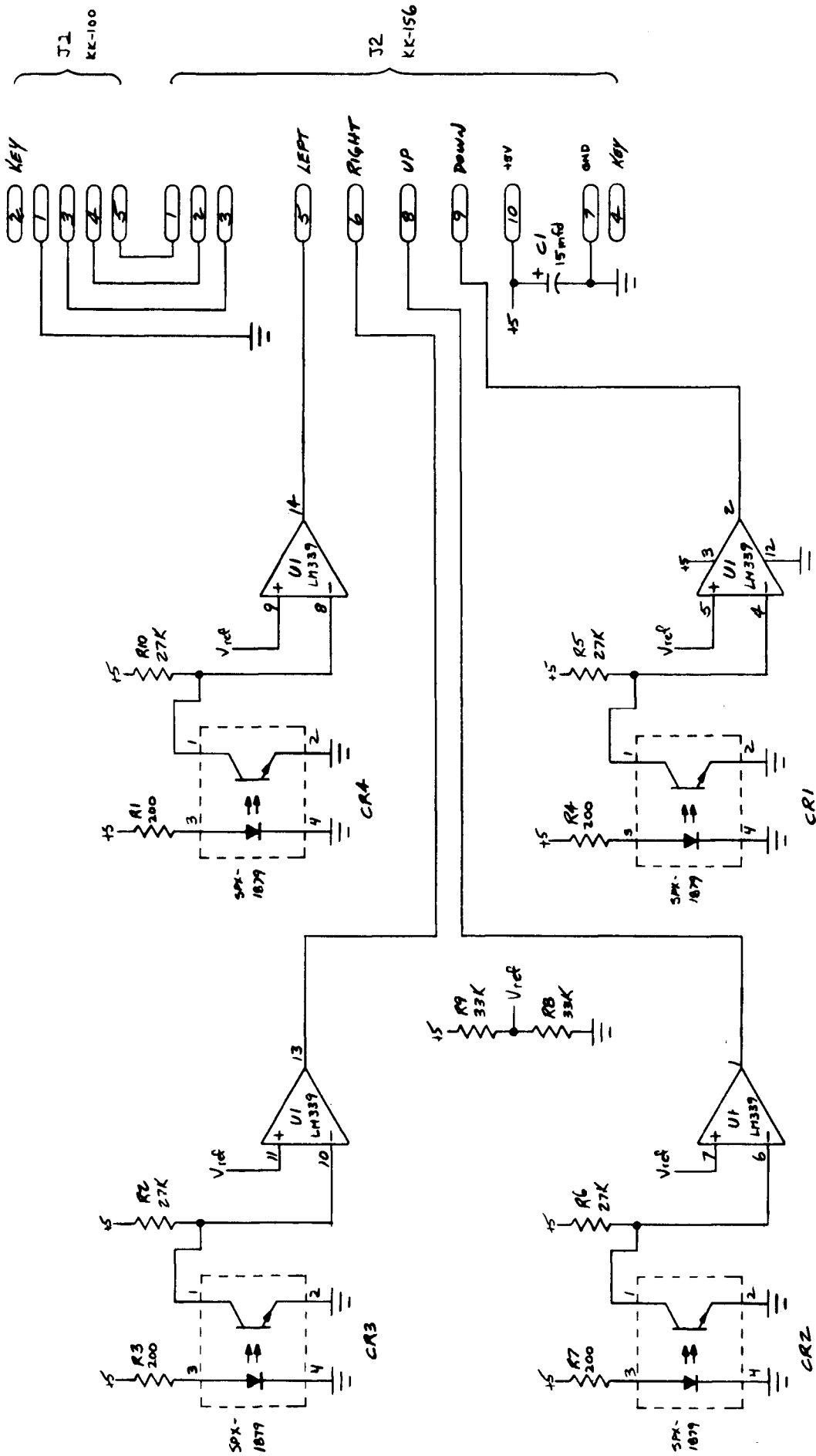

MOS1-00873-A025  
 MIDWAY MFG. CO.  
**CONTROL GRIP PC ASSY**  
**A082-91379-A000**

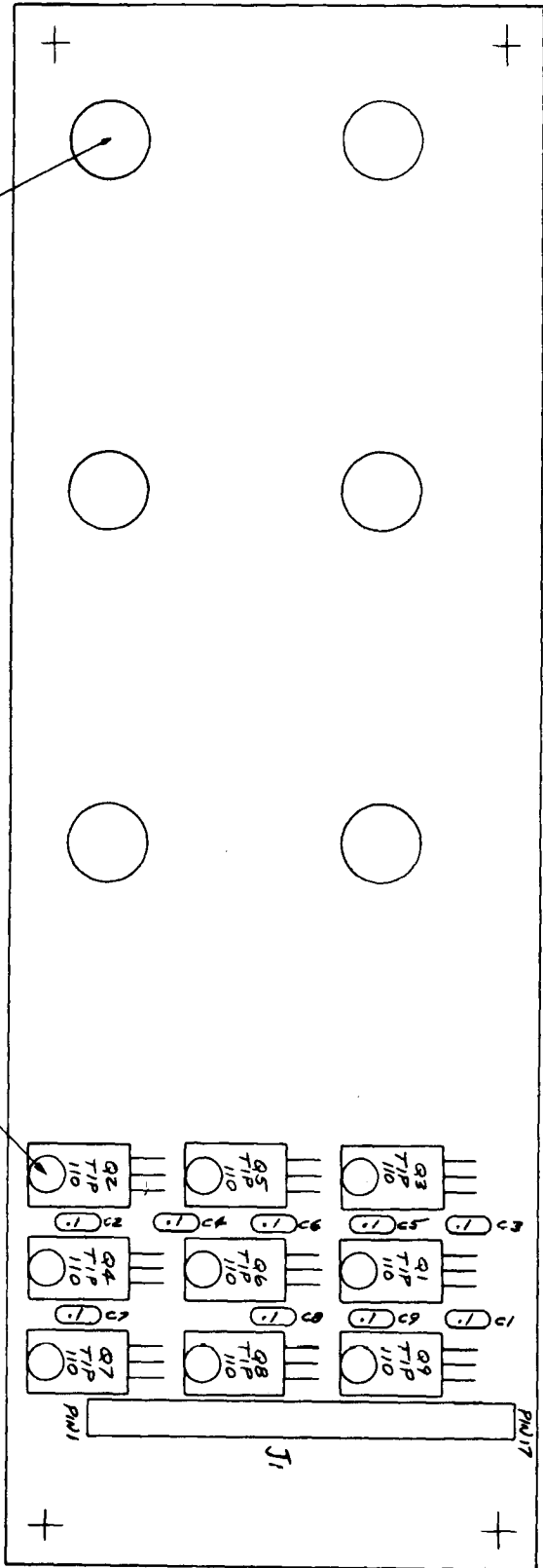

#161 LAMP WITH  
# 0017-00031-0029 SOCKET  
( 6 PLACES )

COMPONENT SIDE VIEW

OPTIONAL MTC. HWK.  
METAL SNMP # 0017-00007-0134  
( 9 PLACES )

M051-00873-A028

NO.	REV.	DATE	BY	CHKD.	APP.	
SCALE		2:1				
MATERIAL						
FINISH						
TOLERANCES						
DIM. UNITS						
NO.		MIDWAY MFG. CO.				
TITLE		MIDWAY MFG. CO.				
NO.		LAMP'S DOWN COUNTERS				
REV.		A084 - 91376-A873				
APP. REVISE		1/18/80				

J1

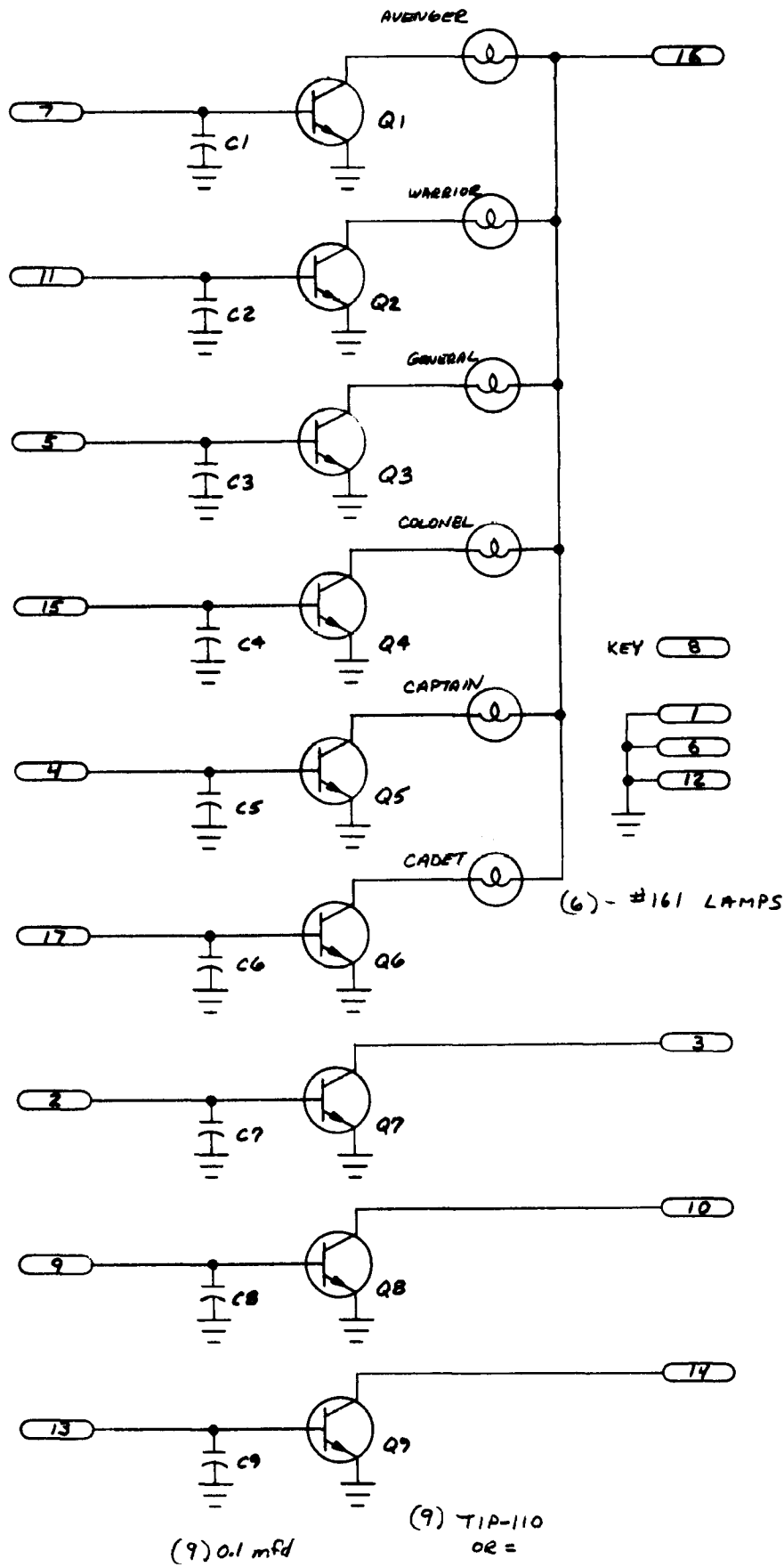

J1

M051-00873-A026

SCALE	DATE	DRAWN BY	MIDWAY MFG. CO.
	9-17-80	OTTO	TITLE DISPLAY BOARD ASSY
MATERIAL	FINISH		FOR GOLF UPRIGHT
FOR APPROVAL	REV: 01		NO 804 - 9/376 - A873
REV: 00A			
APPROVAL:			
10.10.81			
PROD RELEASE			

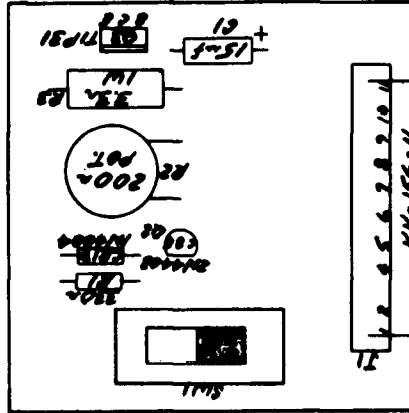

MONO  
AUDIO AMP BOARD ASSEMBLY  
AOBZ-20204-A002

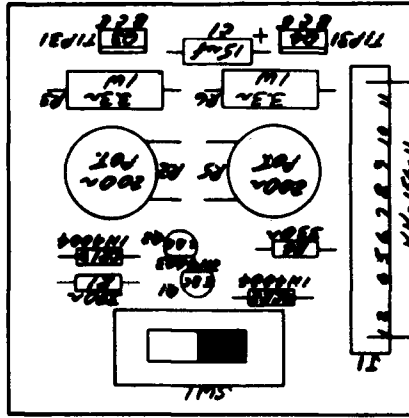

STEREO  
AUDIO AMP BOARD ASSEMBLY  
AOBZ-20203-A002

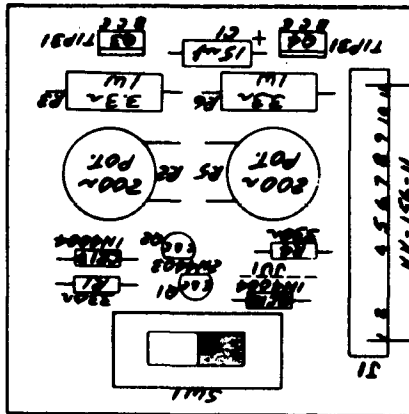

DUAL MONO  
AUDIO AMP BOARD ASSEMBLY  
AOBZ-20205-A002

MO51-00789-A013



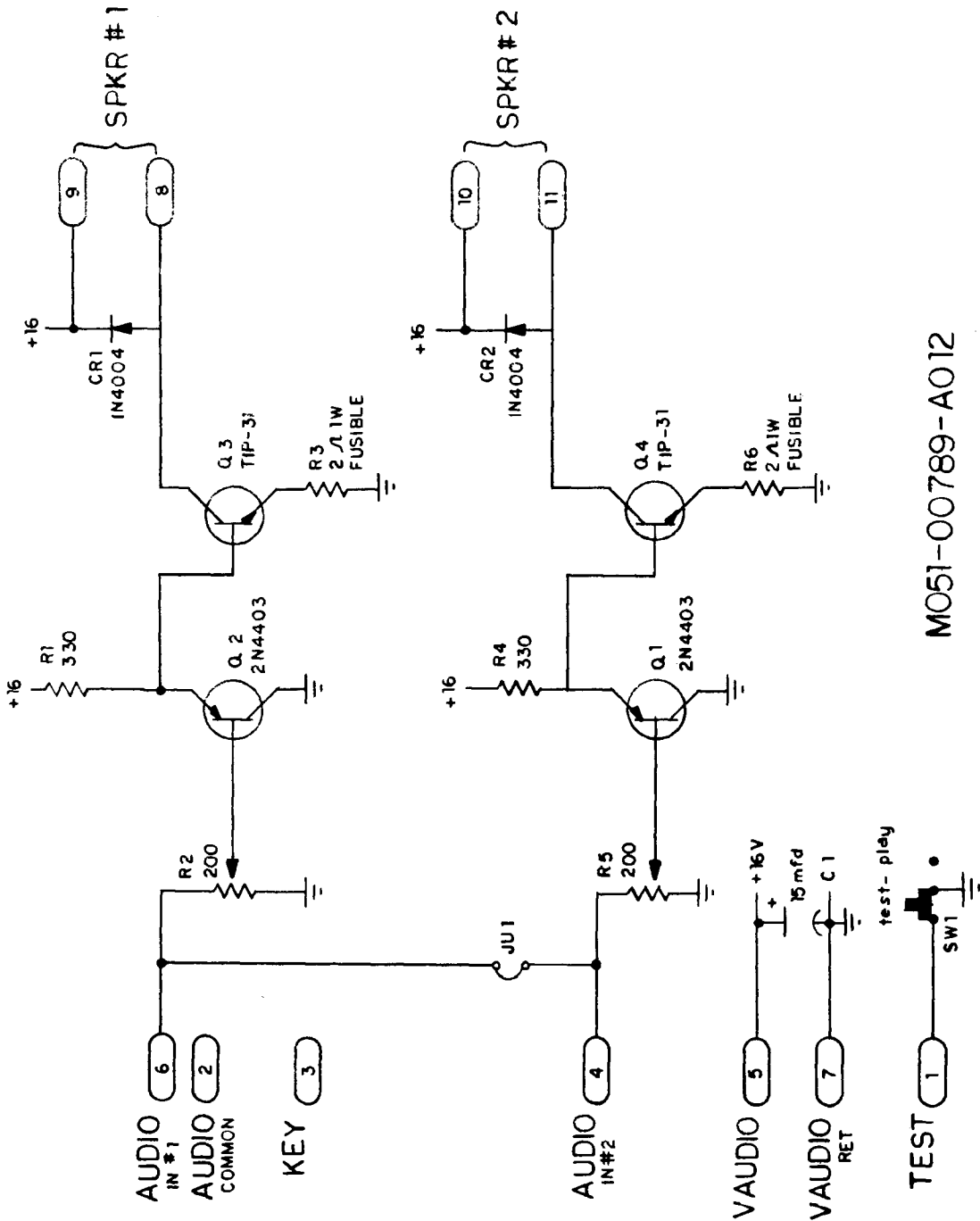

NOTE\*  
 \* FOR MONO 1/2 CIRCUIT SHOWN IS USED  
 FOR DUAL MONO BOTH CIRCUITS ARE  
 USED JUMPER JU1 IS USED  
 FOR STEREO BOTH CIRCUITS ARE  
 USED JUMPER JU1 IS NOT USED

MO51-00789-A012

PART NO. A082-90903-A000	AUDIO AMP BOARD
-----------------------------	-----------------

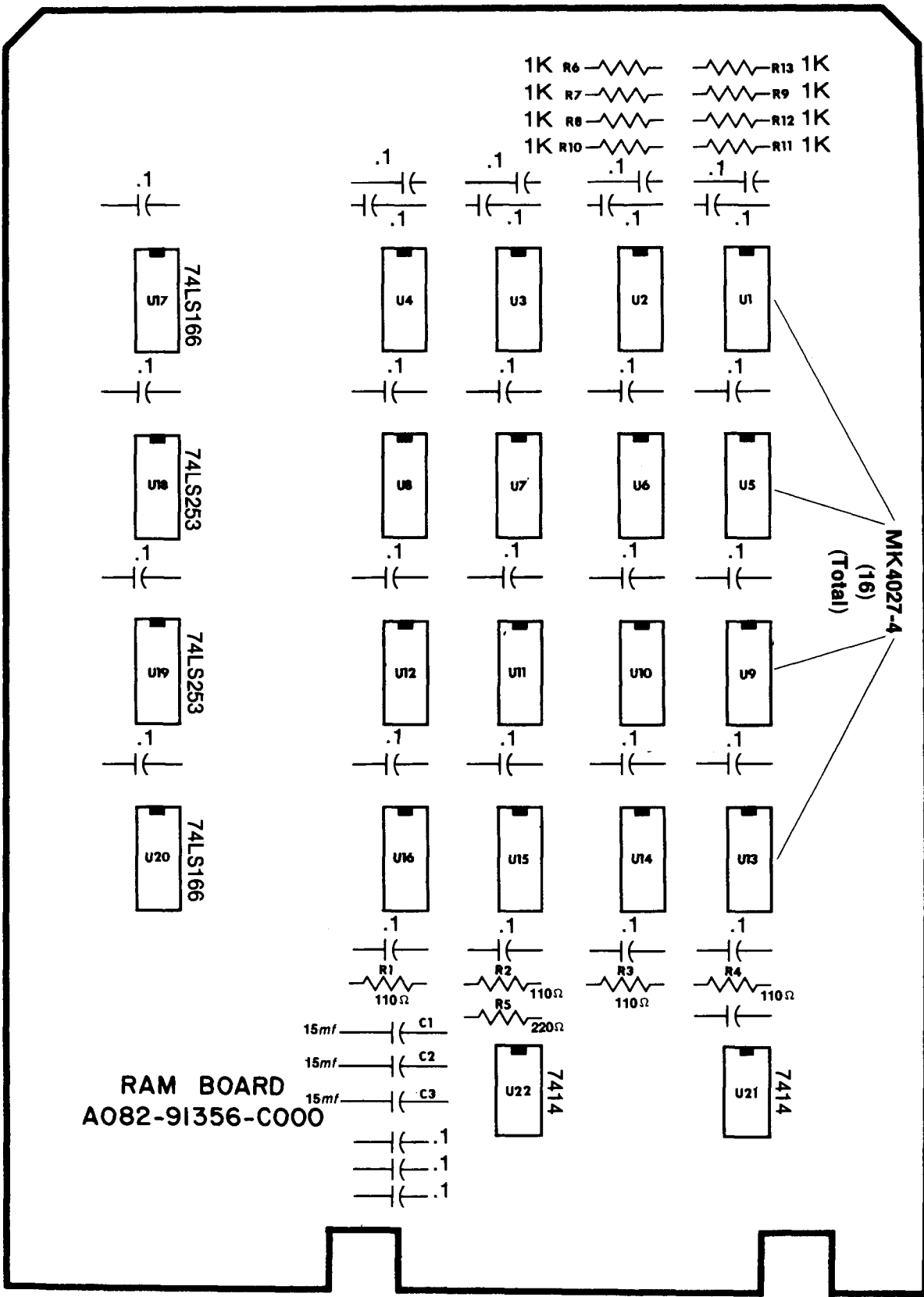

COMPONENT PART NO. M051-00789-C003

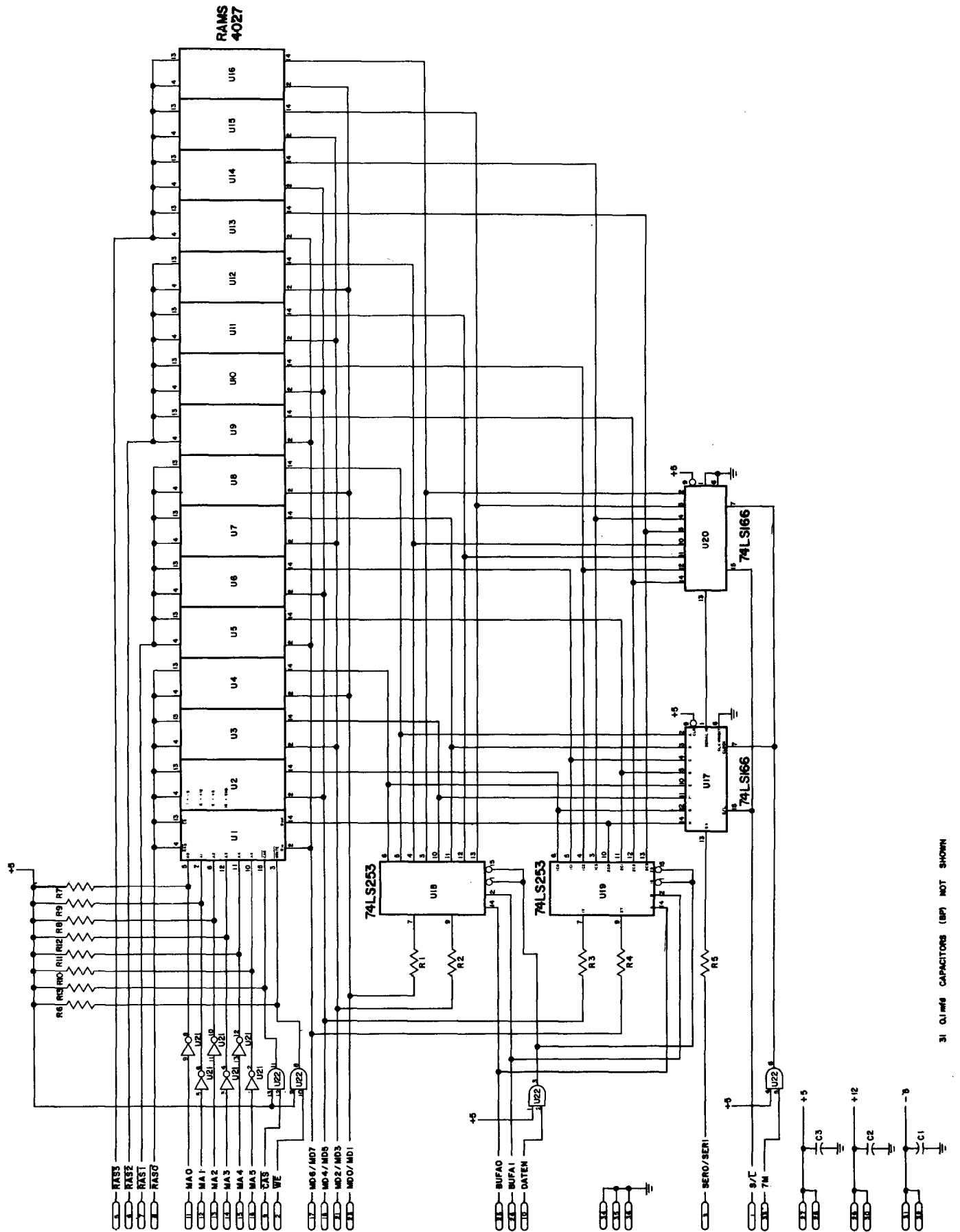

31 0.1 mfd CAPACITORS (BP) NOT SHOWN

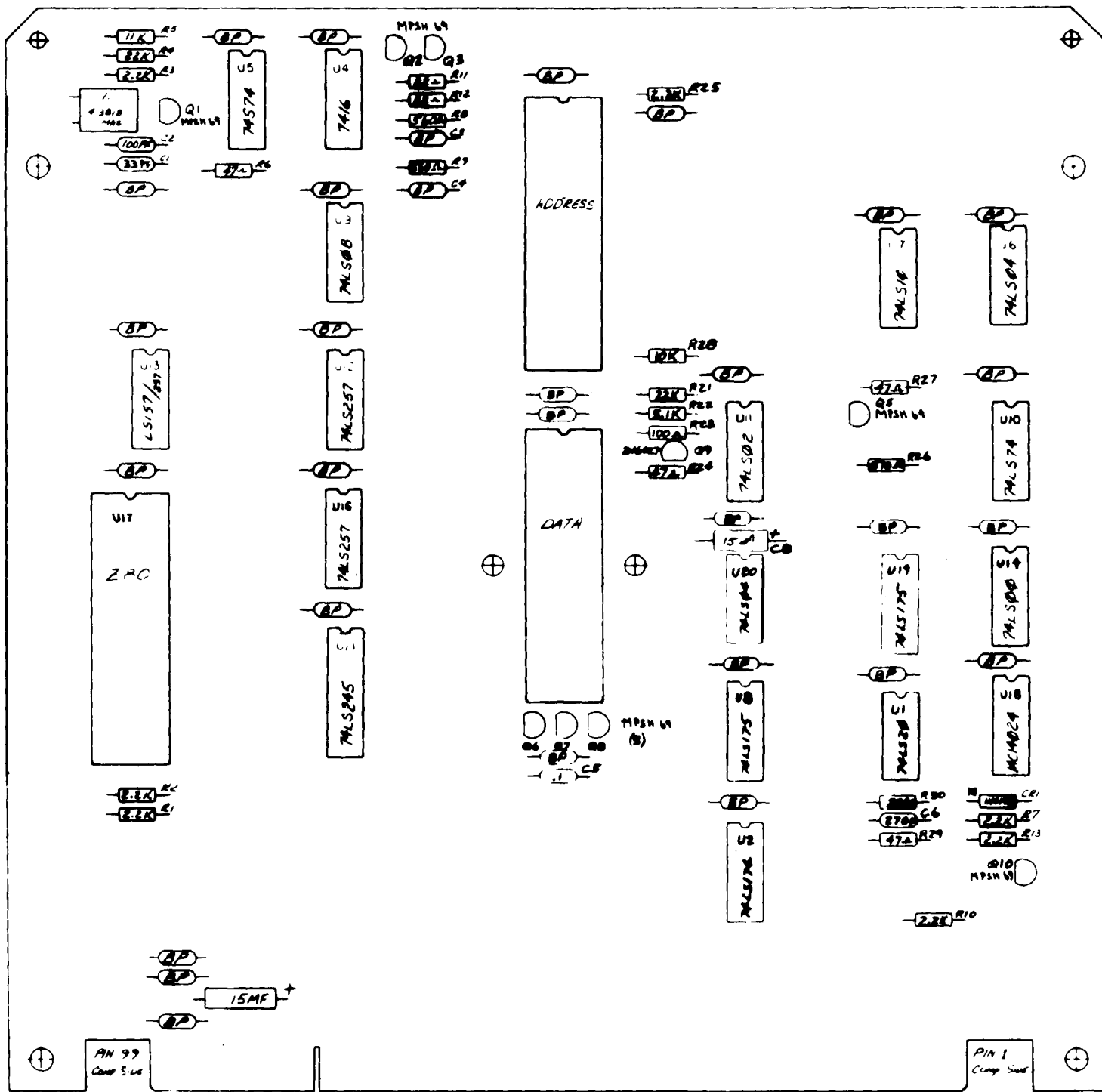

Component Side

M051-00789-F006

REV	DATE	BY	CHKD	APP'D	QTY
1	3-18-80	2-1	2-7	KJF	
C	3-18-80				
D	4-18-80				
E	7-15-80				
MIDWAY MFG. CO.					
CPU BOARD					
CommCard Rack					
A062-91954-F000					

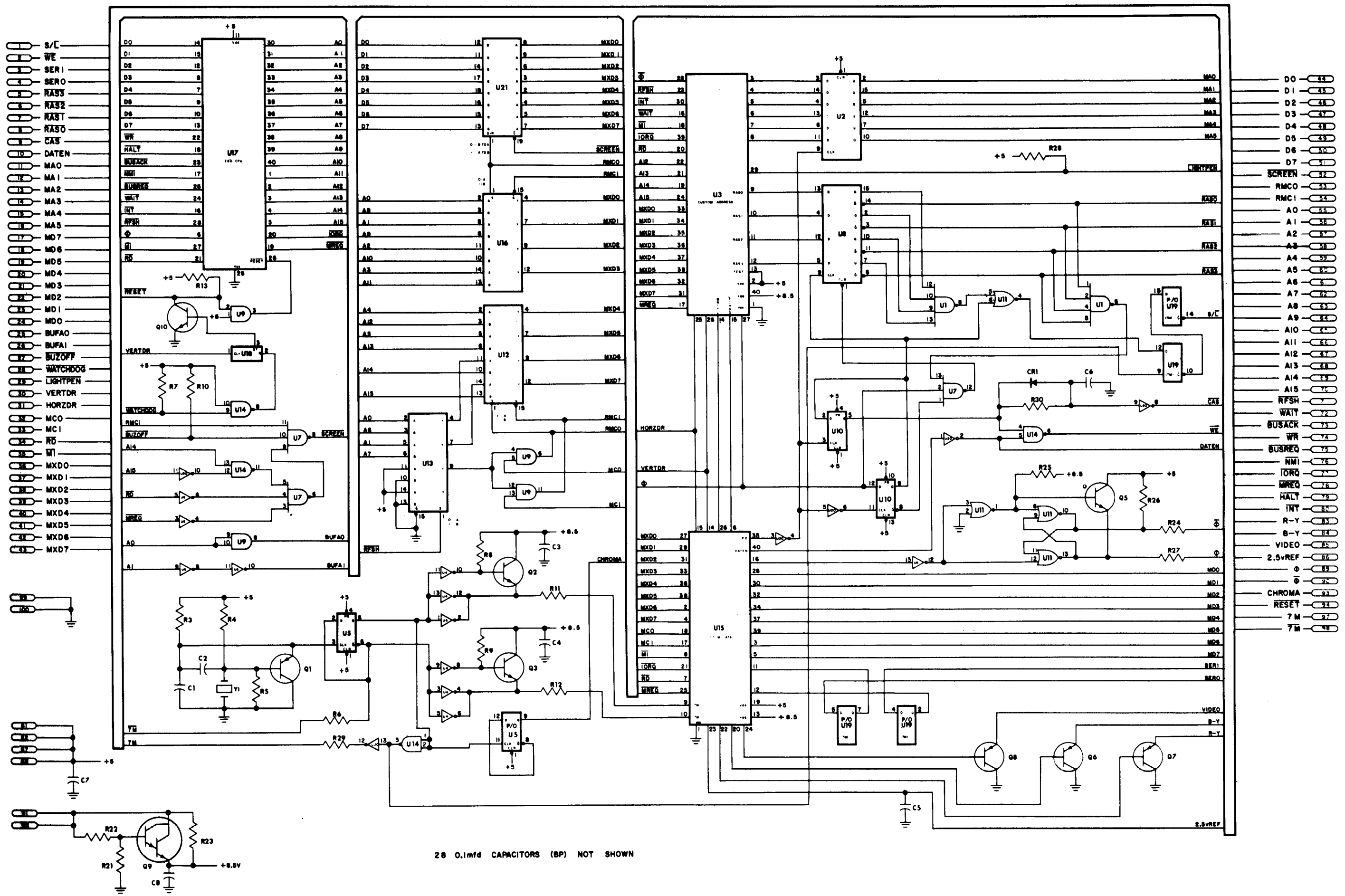

28 0.1µfd CAPACITORS (BP) NOT SHOWN

A082-91354-F000  
M051-00789-F005

CPU BOARD

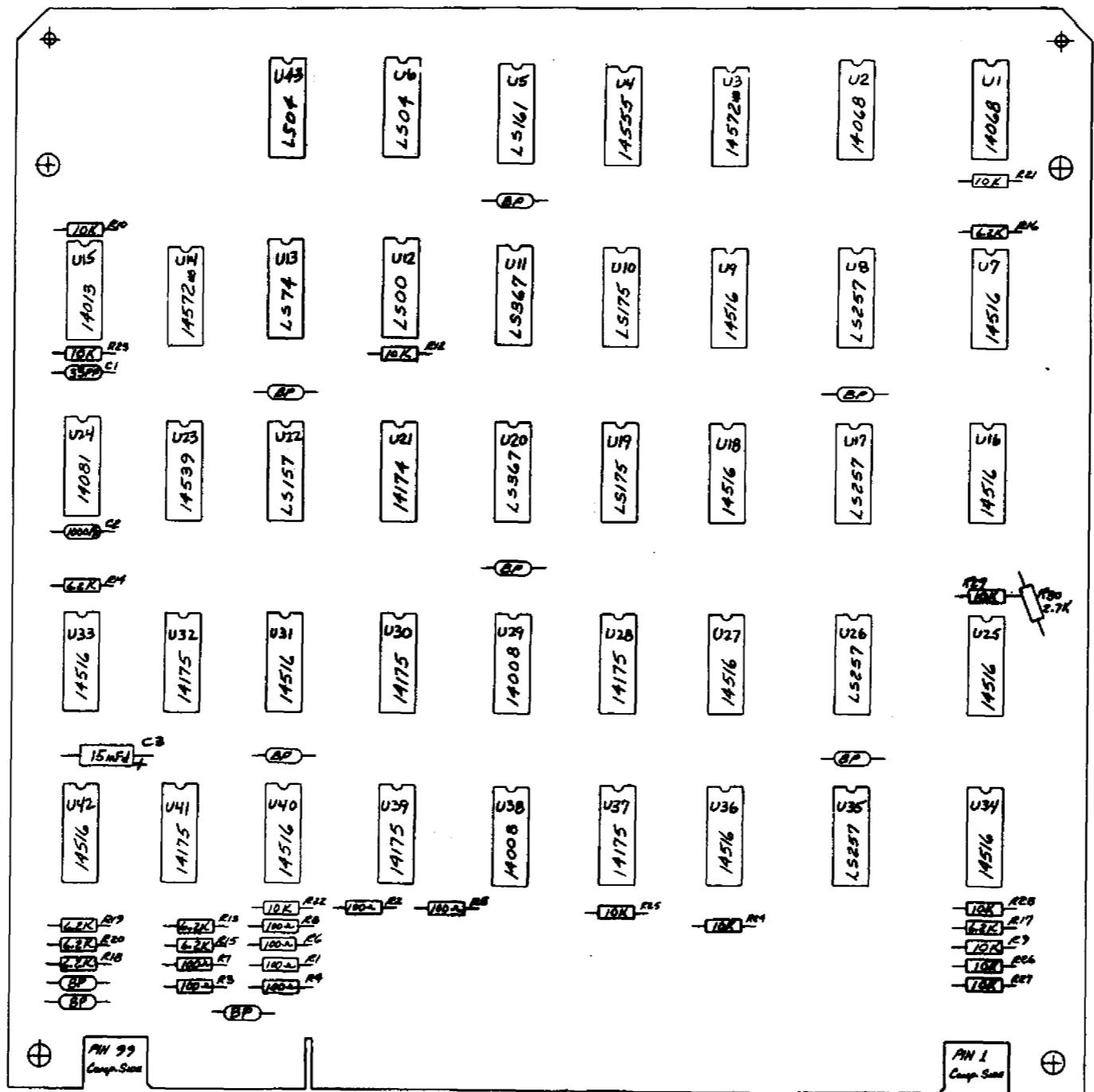

COMPONENT SIDE  
 AOB2-91355-000  
 PATTERN BOARD  
 COMM. CARD RACK

MIDWAY MFG. CO.
PATTERN BOARD
Comm. Card Rack
AOB2-91355-000

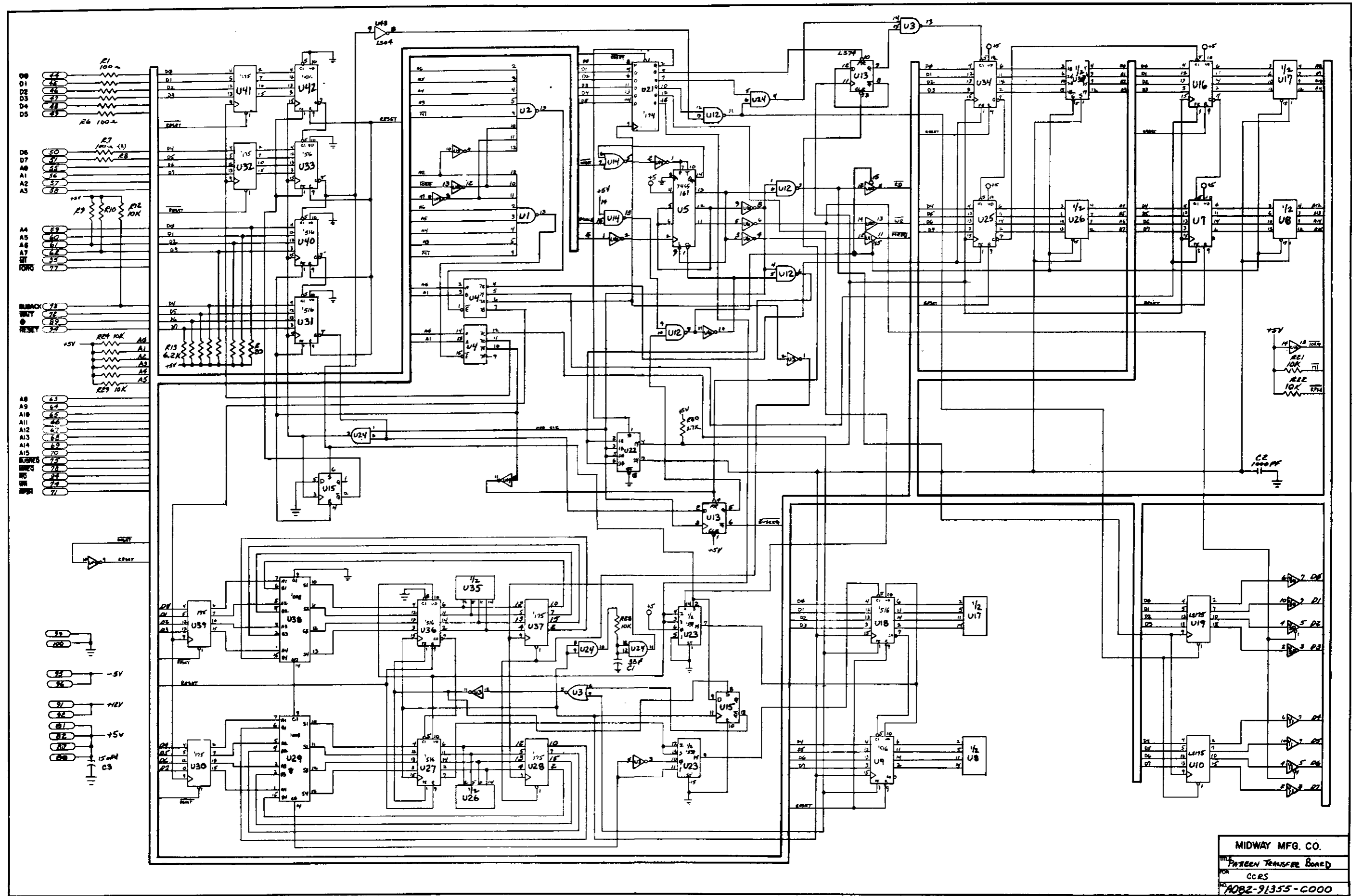

MIDWAY MFG. CO.  
 GREEN TRANSFER BOARD  
 FOR  
 CCBS  
 A082-91355-000

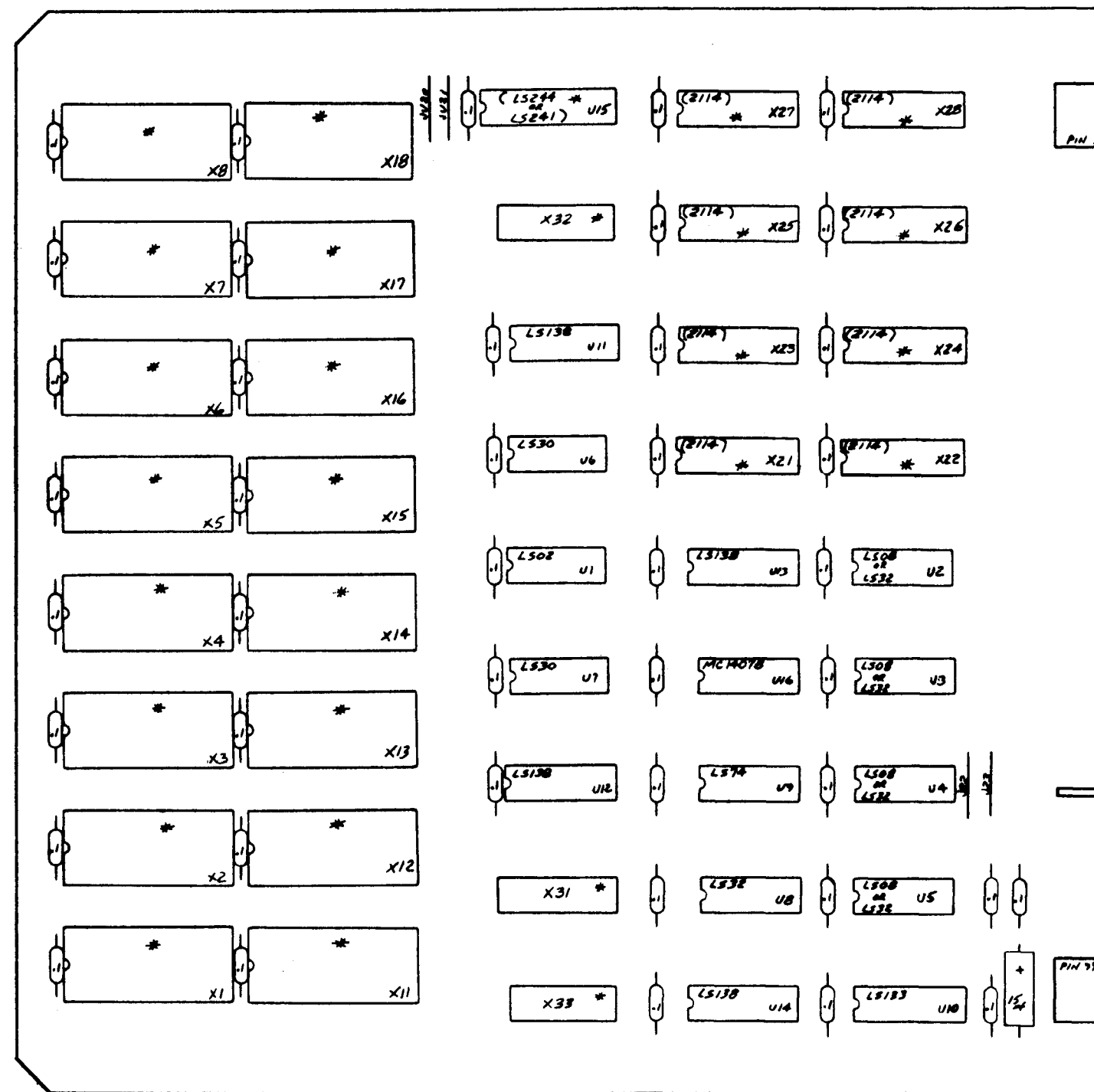

COMPONENT SIDE

\* - DENOTES WHICH POSITION RECEIVES I.C. SOCKET.

M051-00873 - A032

					MIDWAY MFG. CO.
					7002-91364-0000

DOMESTIC



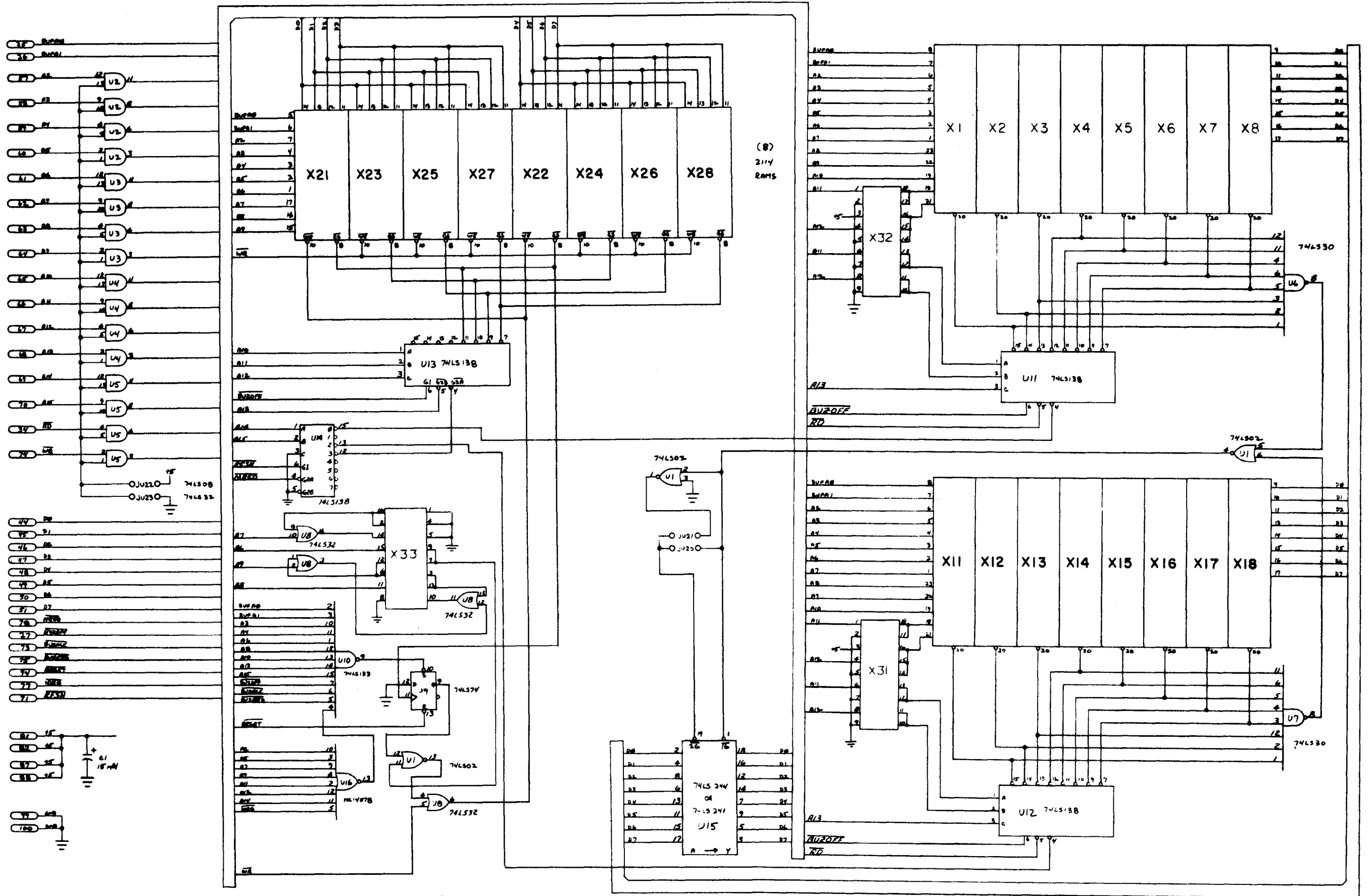

NOT USED

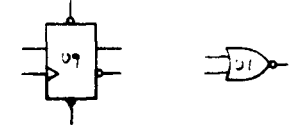

M051-00873-A033

REV	DATE	DESIGNED BY	MIDWAY MFG. CO.
			THE RAM/RAM BOARD
			GORE
			A992-71364-R000

DOMESTIC

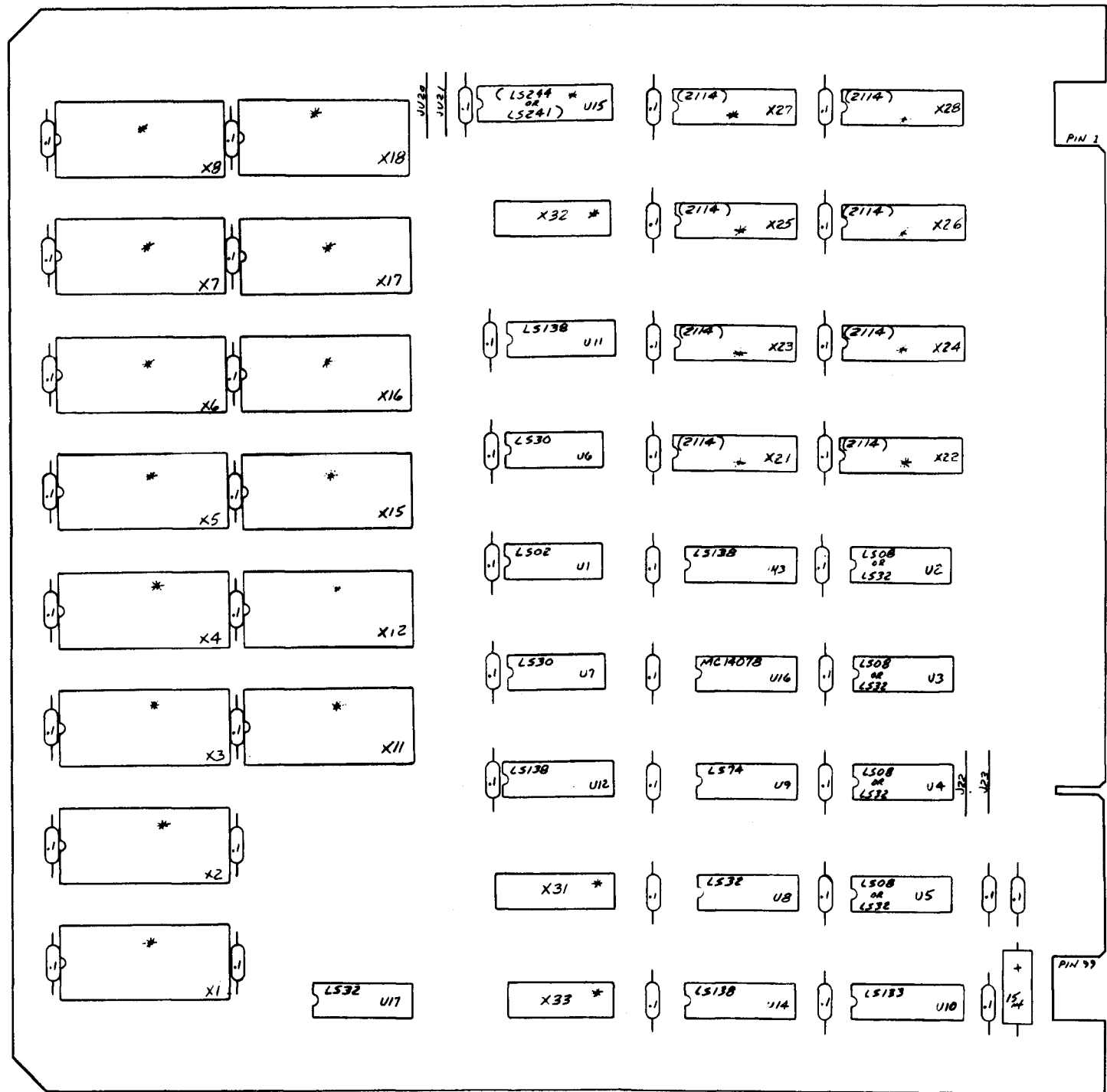

COMPONENT SIDE

\* - DENOTES WHICH POSITION RECEIVES J.C. SOCKET.

M051-00073-A031

SCALE	DATE	DESIGNED BY	MIDWAY MFG. CO.
1/16"	1/13/54	WJ	
MATERIAL	FINISH	TITLE	RAM/ROM AD (44K)
NO. PARTS	NO. OF SHEETS	NO.	9082-91374-A000
PROJ. ENGINEER	DATE	REVISION	

FOREIGN

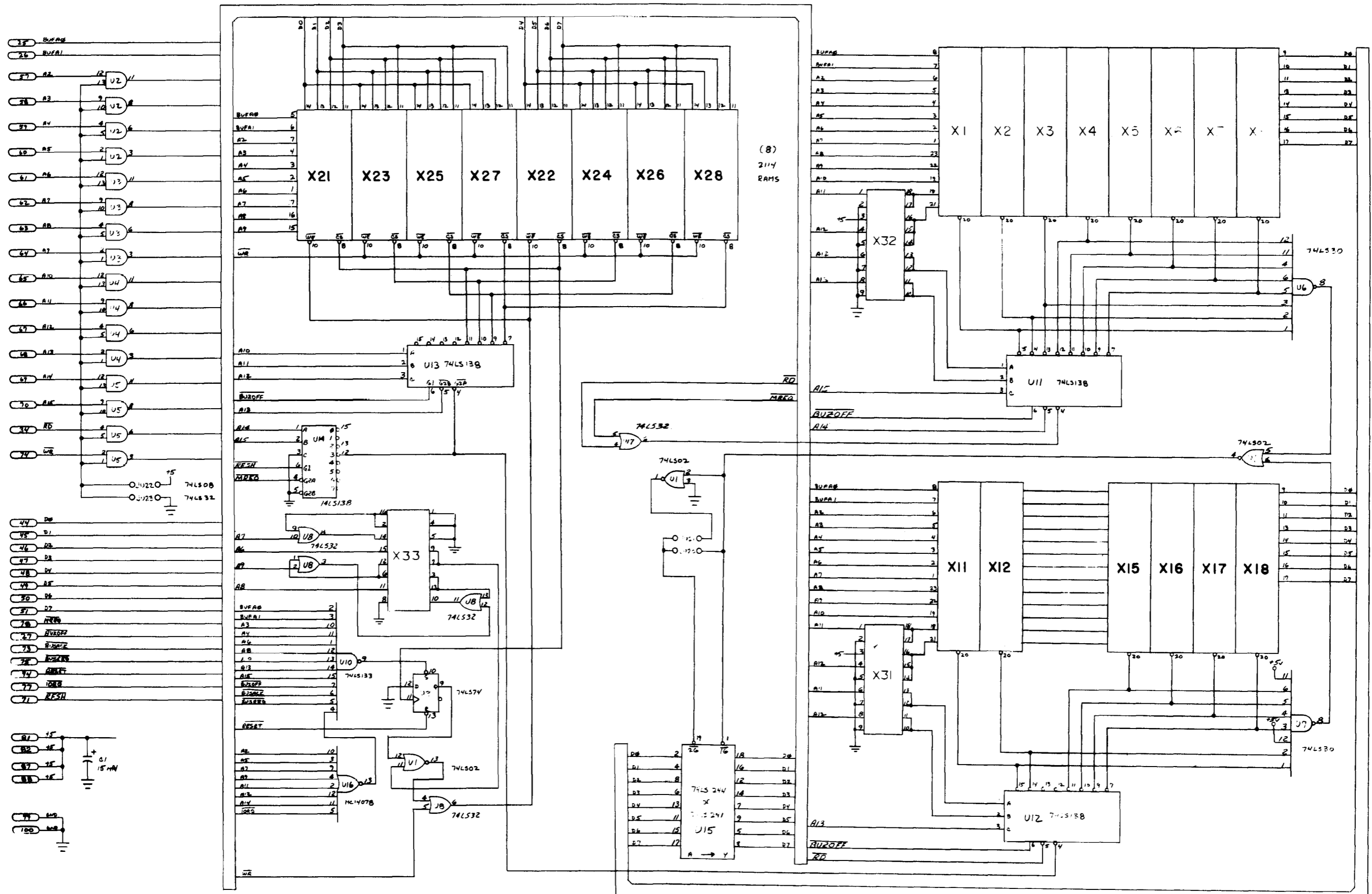

NOT USED

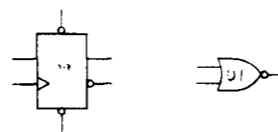

M051-00873-A034

SCALE	DATE	DRAWN BY	MIDWAY MFG. CO.
NONE	7-20-80	OTO	
MATERIAL	FRESH	TITLE	ROM/RAM CARD (44K)
REL. NO.	REV. NO.	FOR	CCBS
PROJ. NO.	NO. IN SET	NO.	A0B2-91374-A000

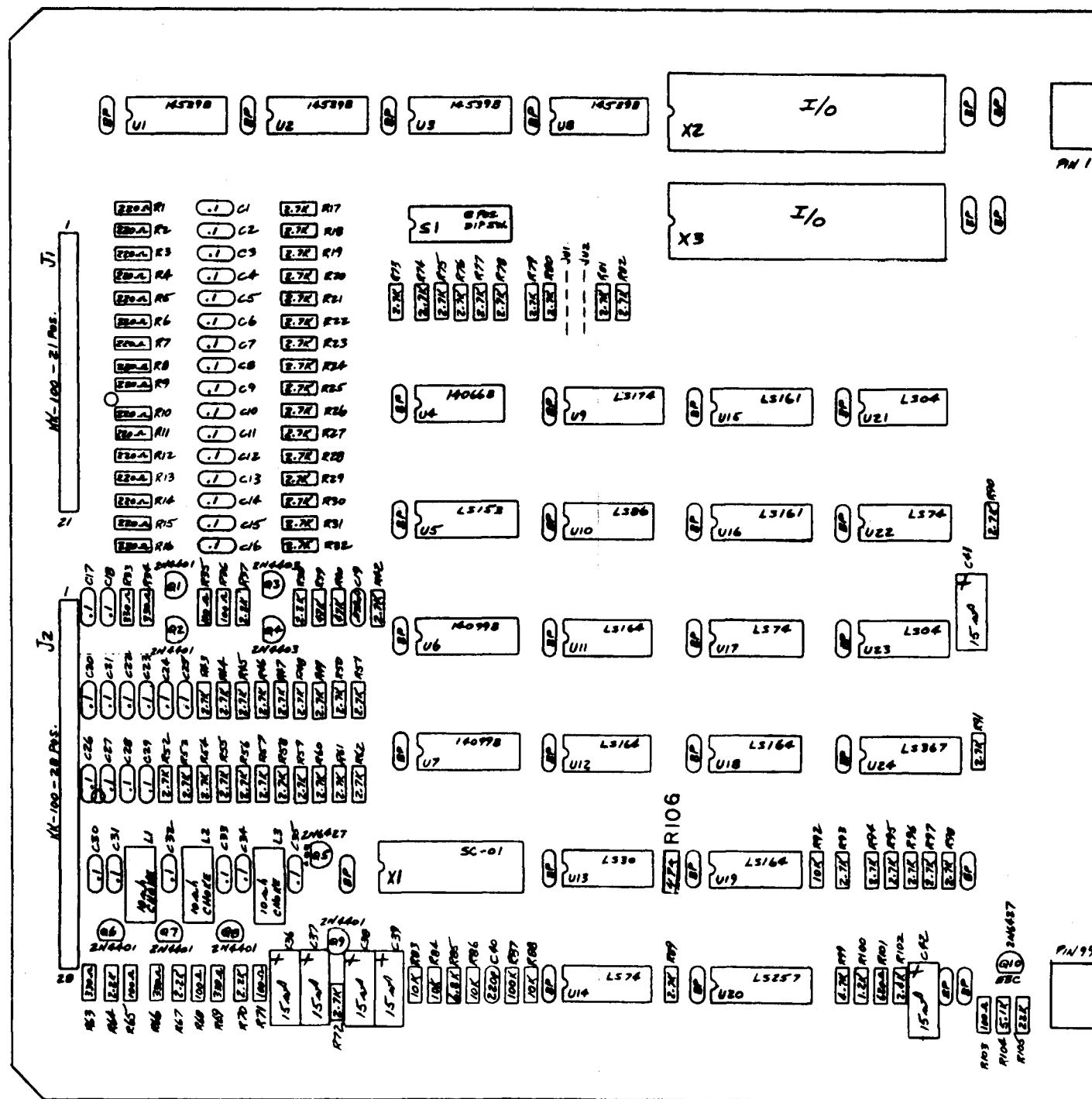

COMPONENT SIDE VIEW

M051-00873-C038

REV	DATE	BY	CHKD	QTY	UNIT	PRICE	TOTAL	REMARKS
1-29-88								
MIDWAY MFG. CO.								
CORP GAME BD								
CCR								
A087-90708-C073								

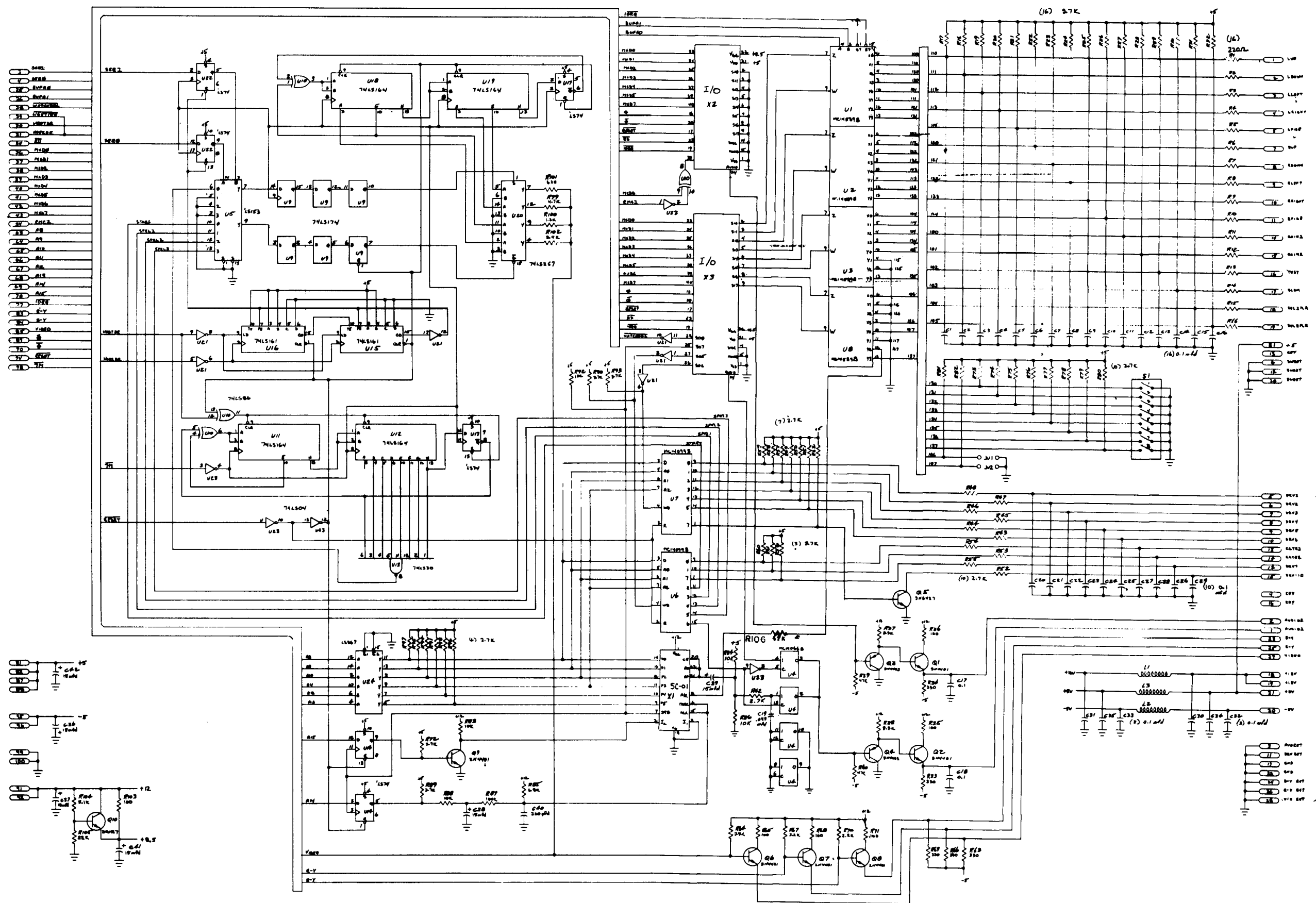

\*C VERSION LOGIC HAS 47K RESISTOR THAT IS IN TRACE OF PIN-8 OF SC-01 IN THE B VERSION THE 47K IS SHORTED

GOLF GAME BOARD  
A084-90708-C873

M051-00873-C024

# 19" COLOR MONITOR SCHEMATIC DIAGRAM

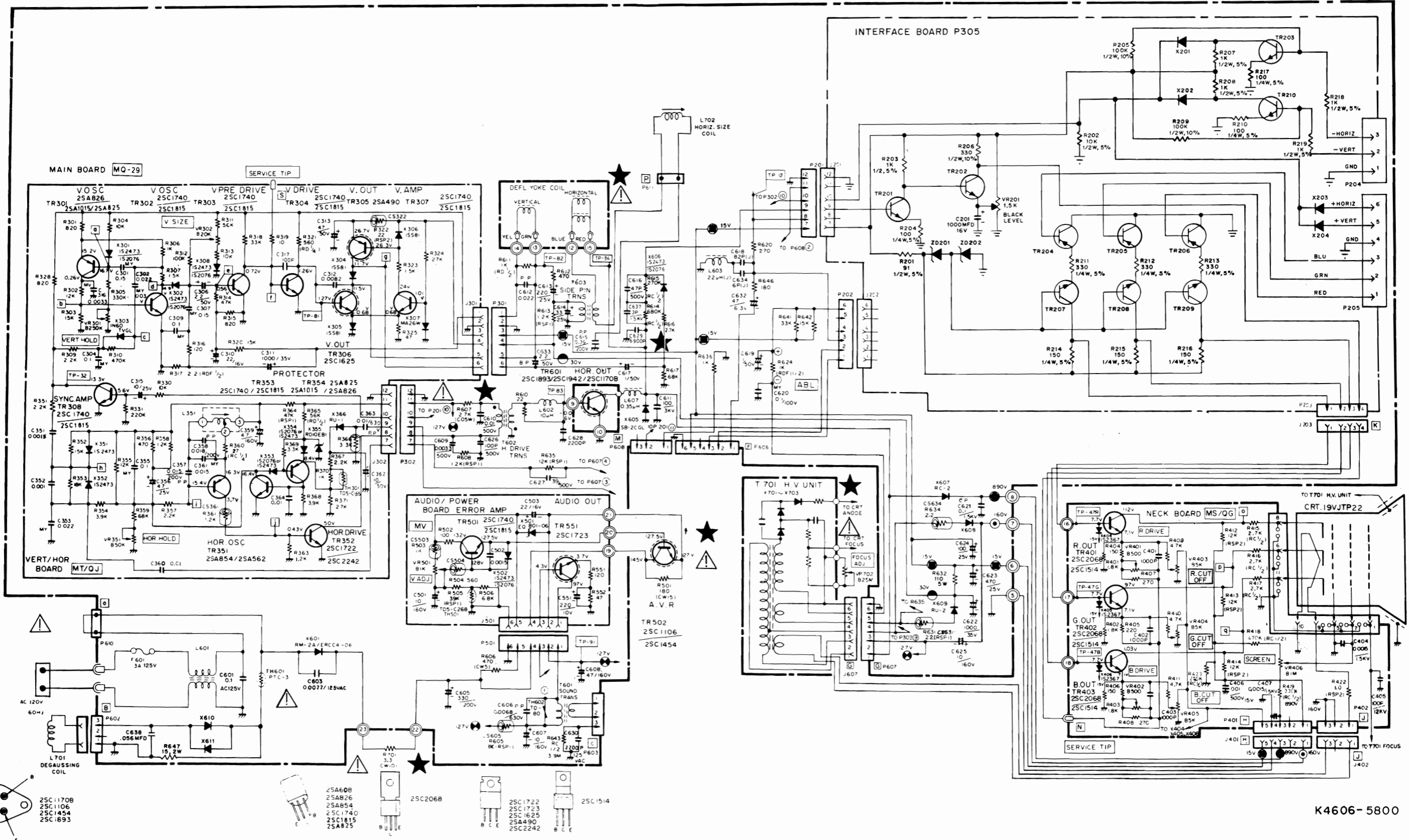

K4606-5800

## VERT/HOR BOARD (MT/QJ)

Ref. No.	Part No.	Description	Ref. No.	Part No.	Description
<b>RESISTORS</b>			<b>CAPACITORS (CONT.)</b>		
R301	203X6500-628	820 Ohm, ± 5%, 1/8W Carbon	C313	203X0025-087	47 uF, 50V Electrolytic
R302	203X6500-902	12k Ohm, ± 5%, 1/8W Carbon	C315	203X0015-082	10 uF, 25V Electrolytic
R303	203X6500-927	15k Ohm, ± 5%, 1/8W Carbon	C316	203X1100-220	3300 uF, 50V, ± 10% Mylar
R304	203X6500-886	10k Ohm, ± 5%, 1/8W Carbon	C317	202X8000-616	100 pF, 50V, ± 10% Ceramic
R305	203X6501-241	330k Ohm, ± 5%, 1/8W Carbon	C351	202X7000-281	1500 pF, 50V, ± 10% Ceramic
R306	203X6500-645	1k Ohm, ± 5%, 1/8W Carbon	C352	202X7000-247	1000 pF, 50V, ± 10% Ceramic
R307	203X6500-689	1.5k Ohm, ± 5%, 1/8W Carbon	C353	203X1100-573	0.022 uF, 50V, ± 10% Mylar
R309	203X6500-724	2.2k Ohm, ± 5%, 1/8W Carbon	C355	203X1100-858	0.1 uF, 50V, ± 10% Mylar
R310	203X6501-285	470k Ohm, ± 5%, 1/8W Carbon	C356	203X0015-105	4.7 uF, 25V Electrolytic
R311	203X6501-065	56k Ohm, ± 5%, 1/8W Carbon	C357	203X1201-013	0.015uF, 200V ± 10% PP
R312	203X6501-126	100k Ohm, ± 5%, 1/8W Carbon	C358	203X1201-034	0.018 uF, 200V, ± 10% PP
R313	203X6001-326	10k Ohm, ± 5%, 1/8W Carbon	C359	203X0040-013	4.7 uF, 160V Electrolytic
R314	203X6501-044	47k Ohm, ± 5%, 1/8W Carbon	C360	202X7000-482	0.01 uF, 50V, ± 10% Ceramic
R315	203X6500-628	820 Ohm, ± 5%, 1/8W Carbon	C361	203X1100-509	0.015 uF, 50V, ± 10% Mylar
R316	203X6500-420	120 Ohm, ± 5%, 1/8W Carbon	C362	203X0025-058	10 uF, 50V Electrolytic
R317	203X6206-441	2.2 Ohm, ± 5%, 1/2W Carbon	C363	203X1205-487	0.01 uF, 630V, ± 10% PP
R319	203X6500-169	100 Ohm, ± 5%, 1/8W Carbon	C364	202X7000-482	0.01 uF, 50V, ± 10% Ceramic
R320	203X6500-927	15k Ohm, ± 5%, 1/8W Carbon			
R321	203X6700-509	560 Ohm, ± 5%, 1/2W Carbon			
R322	203X9100-121	22 Ohm, ± 5%, 2W M.O.			
R323	203X6500-689	1.5K Ohm, ± 5%, 1/8W Carbon			
R324	203X6500-988	27k Ohm, ± 5%, 1/8W Carbon	TR301	200X4082-614	Transistor, 2SA826Q
R325	203X6500-326	47 Ohm, ± 5%, 1/8W Carbon	TR302	200X3174-006	Transistor, 2SC1740Q
R328	203X6500-628	820 Ohm, ± 5%, 1/8W Carbon	TR303	200X3174-006	Transistor, 2SA1740Q
R330	203X6500-886	10k Ohm, ± 5%, 1/8W Carbon	TR304	200X3174-006	Transistor, 2SC1740Q
R331	203X6501-209	220k Ohm, ± 5%, 1/8W Carbon	TR305	200X4049-081	Transistor, 2SA490YLBGLI
R351	203X6500-724	2.2k Ohm, ± 5%, 1/8W Carbon	TR306	200X3162-538	Transistor, 2SC1625YLBGLI
R352	203X6500-927	15k Ohm, ± 5%, 1/8W Carbon	TR307	200X3174-014	Transistor, 2SC1740R
R353	203X6500-944	18k Ohm, ± 5%, 1/8W Carbon	TR308	200X3174-006	Transistor, 2SC1740Q
R354	203X6500-783	3.9k Ohm, ± 5%, 1/8W Carbon	TR351	200X4085-415	Transistor, 2SA854Q
R355	203X6500-902	12k Ohm, ± 5%, 1/8W Carbon	TR352	200X3172-208	Transistor, 2SC1722BKS
R356	203X6500-561	470 Ohm, ± 5%, 1/8W Carbon	TR353	200X3174-006	Transistor, 2SC1740Q
R357	203X6500-724	2.2k Ohm, ± 5%, 1/8W Carbon	TR354	200X4082-614	Transistor, 2SA826Q
R358	203X6500-666	1.2k Ohm, ± 5%, 1/8W Carbon	X301	201X2010-144	Diode, (SI) IS2473-T72
R359	203X6501-088	68k Ohm, ± 5%, 1/8W Carbon	X302	201X2010-144	Diode, (SI) IS2473-T72
R360	203X5500-471	27 Ohm, ± 5%, 1/4W Comp.	X303	200X8000-026	Diode, (GE), IN60TVGL
R361	203X6000-998	1.2k Ohm, ± 5%, 1/8W Carbon	X304	200X8010-165	Diode (SI) ISS81
R363	203X6500-666	1.2k Ohm, ± 5%, 1/8W Carbon	X305	201X2010-165	Diode (SI) ISS81
R364	203X9014-988	47k Ohm, ± 5%, 1W M.O.	X306	201X2010-165	Diode (SI) ISS81
R365	203X6700-989	56k Ohm, ± 5%, 1/2W Carbon	X307	200X8010-102	Diode (SI) MA26W
R366	203X6001-148	3.3k Ohm, ± 5%, 1/8W Carbon	X308	200X8010-094	Diode (SI) IS2473
R367	340X2222-734	2.2k Ohm, ± 5%, 1/2W Carbon	X351	201X2010-144	Diode (SI) IS2473-T72
R368	203X6500-785	3.9k Ohm, ± 5%, 1/8W Carbon	X352	201X2010-144	Diode (SI) IS2473-T72
R369	203X6500-762	3.3k Ohm, ± 5%, 1/4W Carbon	X353	201X2010-144	Diode (SI) IS2473-T72
R370	302X6100-961	1k Ohm, ± 5%, 1/4W Carbon	X354	201X2010-144	Diode (SI) IS2473-T72
R371	203X6104-751	2.7k Ohm, ± 5%, 1/4W Carbon	X355	200X8220-851	Diode (Zener) RD10EBI
VR301	204X2122-093	Varistor, 250K Ohm, Vert. Hold	X366	200X8100-130	Diode (HS) RU-1 0.3 US
VR302	204X2114-065	Varistor, 20K Ohm, Vert. Size			
VR351	204X2114-059	Varistor, 50K Ohm, Hor. Hold			
<b>CAPACITORS</b>			<b>SEMICONDUCTORS</b>		
C301	203X1100-928	0.15 uF, 50V, ± 10% Mylar	J301	204X9300-958	Socket, 6 Pin
C302	203X1100-573	0.022 uF, 50V, ± 10% Mylar	J302	204X9300-958	Socket, 6 Pin
C304	203X1100-858	0.1 uF, 50V, ± 10% Mylar	P301	204X9601-195	Plug, 6 Pin
C306	203X0025-026	2.2 uF, 50V, Electrolytic	P302	204X9601-195	Plug, 6 Pin
C307	203X1100-928	0.15 uF, 50V, ± 10% Mylar	TH301	201X0000-534	Thermistor
C309	203X1100-858	0.1 uF, 50V, ± 10% Mylar			
C310	203X0010-011	22 uF, 16V Electrolytic			
C311	203X0020-099	1000 uF, 35V Electrolytic			
C312	202X7000-469	0.0082 uF, 50V, ± 10% Ceramic	L351	201X5200-091	Coil, Horiz. Osc.
<b>POWER BOARD (MV)</b>			<b>MISCELLANEOUS</b>		
<b>RESISTORS</b>			<b>TRANSFORMERS &amp; COILS</b>		
R501	204X1725-052	180 Ohm, ± 10%, 15W WW	C503	203X0010-011	22 uF, 16V Electrolytic
R502	203X6000-608	100 Ohm, ± 5%, 1/8W Carbon	C551	203X0005-046	220 uF, 10V Electrolytic
R503	203X6000-960	1k Ohm, ± 5%, 1/8W Carbon			
R504	203X6000-879	560 Ohm, ± 5%, 1/8W Carbon	TR501	200X3174-006	Transistor, 2SC1740Q
R505	203X9014-965	39k Ohm, ± 5%, 1W M.O.	★ TR502	200X3145-404	Transistor, 2SC1454
R506	203X6500-842	6.8k Ohm, ± 5%, 1/8W Carbon	TR551	200X3172-305	Transistor, 2SC1723
R551	203X6500-420	120 Ohm, ± 5%, 1/8W Carbon	X501	201X2230-042	Diode, (SI) Zener EQB01-06V
VR501	204X2050-001	Varistor Vert. Adj.	X502	201X2010-144	Diode, (SI) IS2473-T72
<b>CAPACITORS</b>			<b>MISCELLANEOUS</b>		
C501	203X0040-020	10 uF, 160V Electrolytic	J501	204X9300-958	Socket, 6 Pin
C502	202X7000-281	1500 pF, 50V, ± 10% Ceramic	P501	204X9601-195	Plug, 6 Pin
			TH501	201X0000-618	Thermistor

## NECK BOARD (MS/QG)

Ref. No.	Part No.	Description	Ref. No.	Part No.	Description
<b>RESISTORS</b>					
R401	203X6500-709	1.8k Ohm ± 5% 1/8W Carbon	C403	202X7000-247	1000 pF, 50V, 10% Ceramic
R402	203X6500-709	1.8k Ohm ± 5% 1/8W Carbon	C404	202X7110-019	1500 pF, 2kV ± 10% Ceramic
R403	203X6500-709	1.8k Ohm ± 5% 1/8W Carbon	C405	202X7150-018	100 pF, 12kV, ± 10% Ceramic
R404	203X6500-447	150 Ohm ± 5% 1/8W Carbon	C406	202X7050-483	.01 uF, 500V, ± 10% Ceramic
R405	203X6500-481	220 Ohm ± 5% 1/8W Carbon	C407	202X7110-019	1500 pF, 2kV ± 10% Ceramic
R406	203X6500-447	150 Ohm ± 5% 1/8W Carbon	C408	202X8000-550	68 pF, 50V, ± 10% Ceramic
R407	203X6500-508	270 Ohm ± 5% 1/8W Carbon	C409	202X8000-550	68 pF, 50V, ± 10% Ceramic
R408	203X6500-508	270 Ohm ± 5% 1/8W Carbon	C410	202X8000-550	68 pF, 50V, ± 10% Ceramic
R409	203X6500-800	4.7k Ohm ± 5% 1/8W Carbon			
R410	203X6500-800	4.7k Ohm ± 5% 1/8W Carbon			
R411	203X6500-800	4.7k Ohm ± 5% 1/8W Carbon			
R412	203X9104-809	12k Ohm ± 5% 2.0W Metal Oxide			
R413	203X9104-809	12k Ohm ± 5% 2.0W Metal Oxide			
R414	203X9104-809	12k Ohm ± 5% 2.0W Metal Oxide			
R415	203X5601-313	2.7k Ohm ± 10% 1/2W Comp.	TR401	200X3206-800	Transistor, 2SC2068, 2SC1514 (R output)
R416	203X5601-313	2.7k Ohm ± 10% 1/2W Comp.	TR402	200X3206-800	Transistor, 2SC2068, 2SC1514 (G output)
R417	203X5601-313	2.7k Ohm ± 10% 1/2W Comp.	TR403	200X3206-800	Transistor, 2SC2068, 2SC1514 (B output)
R418	203X5602-254	470k Ohm ± 10% 1/2W Comp.			
R419	203X5602-185	330k Ohm ± 10% 1/2W Comp.	X404	201X2100-126	Diode, IS2367 (protector)
R422	203X9105-117	1.0 Ohm ± 10% 2W Metal Oxide	X405	201X2100-126	Diode, IS2367 (protector)
R423	203X5102-155	270k Ohm ± 5% 1/4W Carbon	X406	201X2100-126	Diode, IS2367 (protector)
VR401	204X2115-014	500 Ohm Varistor R Drive			
VR402	204X2115-014	500 Ohm Varistor B Drive			
VR403	204X2115-006	5k Ohm Varistor R Cutoff			
VR404	204X2115-006	5k Ohm Varistor G Cutoff			
VR405	204X2115-006	5k Ohm Varistor B Cutoff			
VR406	204X2000-025	1M Ohm Varistor Screen			

### SEMICONDUCTORS

### MISCELLANEOUS

<b>CAPACITORS</b>		
C401	202X7000-247	1000 pF, 50V, 10% Ceramic
C402	202X7000-247	1000 pF, 50V, 10% Ceramic

J401	206X5003-729	Socket, 5 Pin
J402	206X5003-983	Socket, 3 Pin
P401	204X9600-329	Plug, 5 Pin
P402	204X9600-254	Plug, 3 Pin

### ★ 297X2000-072 HIGH VOLTAGE ASSEMBLY (T701)

★ R701	204X1625-058	3.3 Ohm, ± 10% 10W WW Resistor	} Part of T701
VR702	204X3901-125	Focus Control	
X701		Diode (SI HV)	
X702		Diode (SI HV)	
X703		Diode (SI HV)	

### FINAL ASSEMBLY PARTS

★ 88X-0129-506	19VJTP22 Plx Tube
38A5554-000	Assy. Purity Shld/Degaussing
205X9800-256	Lateral/Purity Assembly
★ 202X1110-810	Yoke, Deflection
208X2000-946	CRT Socket
297X2000-072	HV Unit (T701)
6A0397	Plug, Line Cord
9A2753-003	Degaussing Coil (L701)

## INTERFACE BOARD (P305)

(MODEL 19K4606)

### RESISTORS

### SEMICONDUCTORS

R201	340X3910-934	91 Ohm, 5%, 1/2W Carbon
R203	340X3102-934	1k Ohm, 5%, 1/2W Carbon
R204	340X2101-934	100 Ohm, 5%, 1/4W Carbon
R206	340X3331-944	330 Ohm, 10%, 1/2W Carbon
R207	340X3102-934	1k Ohm, 5%, 1/2W Carbon
R208	340X3152-934	1.5k Ohm, 5%, 1/4W Carbon
R209	340X2101-934	100 Ohm, 5%, 1/4W Carbon
R210	340X3102-934	1k Ohm, 5%, 1/2W Carbon
R211	340X2331-934	330 Ohm, 5%, 1/4W Carbon
R212	340X2331-934	330 Ohm, 5%, 1/4W Carbon
R213	340X2331-934	330 Ohm, 5%, 1/4W Carbon
R214	340X2201-934	200 Ohm, 5%, 1/4W Carbon
R215	340X2201-934	200 Ohm, 5%, 1/4W Carbon
R216	340X2201-934	200 Ohm, 5%, 1/4W Carbon
VR201	40X0590-017	1.5k Ohm, Black Level Control

TR201	86X0121-001	Transistor (NPN)
TR202	86X0121-001	Transistor (NPN)
TR203	86X0121-001	Transistor (NPN)
TR204	86X0066-001	Transistor (PNP)
TR205	86X0066-001	Transistor (PNP)
TR206	86X0066-001	Transistor (PNP)
TR207	86X0121-001	Transistor (NPN)
TR208	86X0121-001	Transistor (NPN)
TR209	86X0121-001	Transistor (NPN)
ZD201	66X0040-018	Diode, Zener, 6.8V, 5%, 0.5W
ZD202	66X0040-019	Diode, Zener, 3.9V, 5%, 0.5W

### MISCELLANEOUS

<b>CAPACITORS</b>		
C201	45X0524-038	1000 uF, 16V Electrolytic

J201	204X9300-958	Socket, 6 Pin
J202	204X9300-958	Socket, 6 Pin
J203	206X5019-207	Socket, 4 Pin
P201	204X9601-195	Plug, 6 Pin
P202	204X9601-195	Plug, 6 Pin
P203	204X9600-845	Plug, 4 Pin
P205	6A0393-006	Plug, 6 Pin



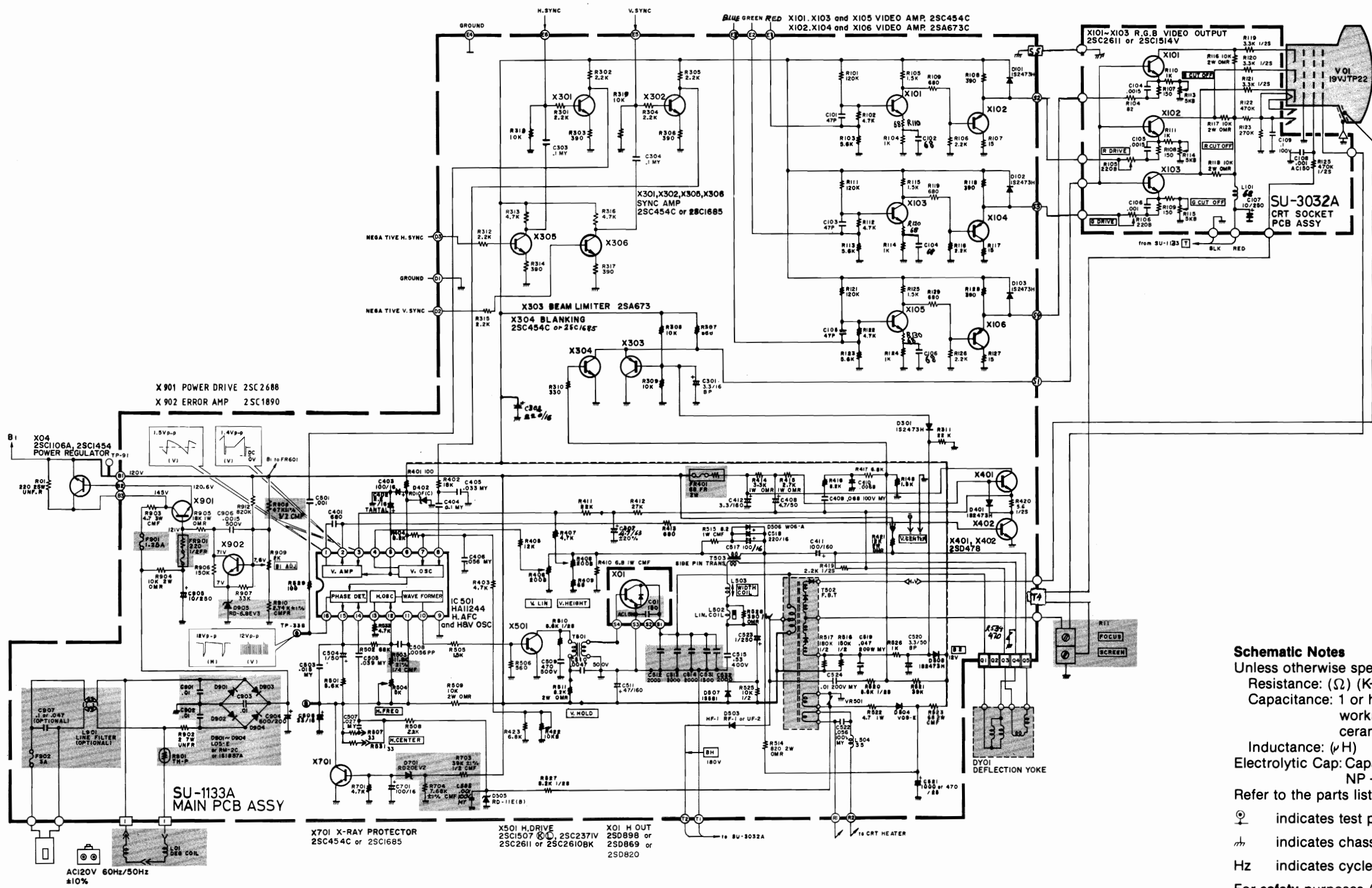

**Schematic Notes**  
 Unless otherwise specified  
 Resistance: ( $\Omega$ ) (K $\rightarrow$ K $\Omega$ , M $\rightarrow$ M $\Omega$ ), 1/4 (W) carbon resistor  
 Capacitance: 1 or higher  $\rightarrow$  (pF), less than 1  $\rightarrow$  ( $\mu$ F)  
 working voltage  $\rightarrow$  50 (V)  
 ceramic capacitor  
 Inductance: ( $\mu$ H)  
 Electrolytic Cap: Capacitance Value ( $\mu$ F)/working voltage (V),  
 NP  $\rightarrow$  non-polar (or bipolar) electrolytic cap.  
 Refer to the parts list for additional component information.

$\odot$  indicates test point connection  
 $\perp$  indicates chassis ground unless otherwise specified  
 Hz indicates cycles per second

For **safety** purposes (and continuing reliability)  
 $\triangle$  replace all components marked with safety symbol with identical type.  
 NOTE: FR  $\rightarrow$  fusible resistor ( $\text{---}\text{---}$ )

00-4147-04  
 G07-CB0

Parts identification on circuit boards:  
 e.g. SU1126A (R107 = R1107)  
 SU3030A (R113 = R3113)

# NOTES

This space is provided for personal notes

## REPLACEMENT PARTS LIST - ELECTROHOME 19" MONITOR

Components identified by the  $\triangle$  symbol in the PARTS LIST and on the Schematic have special characteristics important to safety.

DO NOT degrade the safety of the set through improper servicing.

### Abbreviations for Resistors and Capacitors

#### Resistor

C R : Carbon Resistor  
Comp. R : Composition Resistor  
OM R : Oxide Metal Film Resistor  
V R : Variable Resistor  
MF R : Metal Film Resistor  
CMF R : Coating Metal Film Resistor  
UNF R : Nonflammable Resistor  
F R : Fusible Resistor

#### Capacitor

C Cap. : Ceramic Capacitor  
M Cap. : Mylar Capacitor  
E Cap. : Electrolytic Capacitor  
BP E Cap. : Bi-Polar (or Non-Polar) Electrolytic Capacitor  
MM Cap. : Metalized Mylar Capacitor  
PP Cap. : Polypropylene Capacitor  
MPP Cap. : Metalized PP Capacitor  
PS Cap. : Polystyrol Capacitor  
Tan. Cap. : Tantal Capacitor

NOTE: When ordering replacement parts please specify the part number as shown in this list including part name, and model number. Complete information will help expedite the order.

Use of substitute replacement parts which do not have the same safety characteristics as specified, may create shock, fire or other hazards. For maximum reliability and performance, all parts should be replaced by those having identical specifications.

### SERVICE REPLACEMENT PARTS LIST

Symbol	Description	Part Number
	Main P.C.B. Ass'y	SU-1133A
	CRT Socket P.C.B. Ass'y	SU-3032A
	Purity Shield Ass'y	07-220083-03

**Outside of the P.C.B. Ass'y**

Symbol	Description	Part Number
	Picture Tube 19"	17-7198-03
△	△Deflection Yoke	A29779-D = 21-141-01
	PC Magnet	A75034-B = 29-32-01
△	△Flyback Transf.	A29951-B
△	△HVR	A46600-A
R05	UNF Resistor 220Ω,25W K	QRF258K-221
C04	C Capacitor 150pF, AC1.5KV	QCZ0101-005
X01	Si. Transistor	2SD870
X02	Si. Transistor	2SC1106A
SC	Screw #8- <sup>3</sup> / <sub>8</sub>	31-610818-06
SC	Screw ¼ x ¾ Pix Tube Mtg. (4)	31-601418-12
WA	Pyramidal Lock Washer (4)	33-255-01
	Nut Retainer, Pix Tube Mtg. (4)	33-494-01
	Clip — P.C.B. Support	33-629-02
	Standoff	33-670-010R-02
	Wire Terminal (Gnd. Strap)	34-228-03
	Terminal Lug (Gnd.)	34-33-04
	Groundstrap Assy.	34-574-02
	Grounding Spring	35-212-03
	Wire Hook (Gnd. Strap)	35-3053-02
	Purity Shield Holddown Clamp	35-2348-01
	Support Brkt. RH	35-3890-01
	Support Brkt. LH	35-3890-02
	Chassis Base	38-449-02
	Yoke Wedge (3)	39-1233-01

**Purity Shield Ass'y. Parts List**

Symbol	Description	Part Number
D911, D912	Degaussing Coil	21-1007-30
	Rectifier 1 Amp 600V (2)	28-22-27
	Pin Terminal (2)	34-708-01
	Pin Terminal Housing	34-709-01
	Purity Shield (2 pcs.)	35-3847-01
	Purity Shield (2 pcs.)	35-3847-02
C911	Capacitor 100nF 10% 400V	48-171544-62
R921	Resistor, Wirewound 33Ω, 4W	42-113301-03
	Fire Retardent Term. Strip 4 Lug	34-492-09

**CRT Socket P.C.B. Ass'y (SU-3032A) Parts List**

**Resistors**

Symbol	Description	Part Number
R3105	V R 200	QVZ3234-022
R3106	V R 200	QVZ3234-022
R3113	V R 5K	QVZ3234-053
R3114	V R 5K	QVZ3234-053
R3115	V R 5K	QVZ3234-053
R3116	OM R 10KΩ2W J	QRG029J-103
R3117	OM R 10KΩ2W J	QRG029J-103
R3118	OM R 10KΩ2W J	QRG029J-103
R3119	Comp. R 3.3KΩ½W K	QRZ0039-332
R3120	Comp. R 3.3KΩ½W K	QRZ0039-332
C3121	Comp. R 3.3KΩ½W K	QRZ0039-332

**Capacitors**

Symbol	Description	Part Number
C3107	E Cap. 10uF 250V A	QEW53EA-106
C3108	C Cap. 1000pF DC1400V P	QCZ9001-102M

**Coils**

Symbol	Description	Part Number
L3101	Peaking Coil	QQL043K-101

**Semiconductors**

Symbol	Description	Part Number
X3101	Si. Transistor	2SC1514VC
X3102	Si. Transistor	2SC1514VC
X3103	Si. Transistor	2SC1514VC

**Miscellaneous**

Symbol	Description	Part Number
△	△CRT Socket	A76068

**Main PCB Ass'y (SU-1133A) Parts List****Resistors**

Symbol	Description	Part Number
R1406	V R 200Ω	QVZ3230-002
R1408	V R 200Ω	QVZ3230-002
R1410	CMF R 6.8Ω1W J	QRX019J-6R8
R1414	OM R 3.3KΩ1W J	QRG019J-332
R1415	OM R 2.7KΩ1W J	QRG019J-272
R1421	OM R 12KΩ2W J	QRG026J-123Z
R1422	V R 10KΩ	QVZ3230-014
△FR1401	△F R 68Ω2W K	QRH024K-680M
△R1503	△CMF R 11.8KΩ¼W +1%	QVR142F-1182
R1504	V R 5KΩ	QVZ3230-053
R1509	OM R 10KΩ2W J	QRG026J-103Z
R1512	OM R 8.2KΩ2W J	QRG026J-822Z
R1514	OM R 820Ω2W J	QRG026J-821Z
R1515	CMF R 8.2Ω1W J	QRX019J-8R2
R1522	CMF R 4.7Ω1W J	QRX019J-4R7
R1523	OM R 68Ω2W J	QRG026J-680Z
R1528	OM R 390Ω1W J	QRG019J-391
R1534	ZN R	ERZ-C05ZK471
VR1501	ZN R	ERZ-C05DK271
△R1703	△CMF R 39Ω½W +1%	QVR122F-3902
△R1704	△CMF R 7.68KΩ¼W +1%	QVR142F-7681
△R1901	△Posistor	A75414
R1902	UNF R 2Ω7W K	QRF076K-2R0
R1903	CMF R 4.7Ω3W J	QRX039J-4R7
R1904	OM R 10KΩ2W J	QRG026J-103Z
R1905	OM R 18KΩ1W J	QRG019J-183
△Q1908	△CMF R 47Ω½W +1%	QVR122F-470Z
△R1909	V R 2KΩ	QVP5A0B-023E
R1910	△CMF R 2.74KΩ¼W +1%	QVR142F-2741
△FR1901	△F R 220Ω½W K	QRH124K-221M

**Capacitors**

Symbol	Description	Part Number
C1301	BPE Cap. 3.3uF 50V A	QEN61HA-335Z
C1402	Tan. Cap. 2.2uF 16V K	QEE51CK-225B
C1407	E Cap. 4.7uF 6.3V A	QEW51JA-475
C1411	E Cap. 100uF 160V A	QEW52CA-107
C1412	E Cap. 3.3uF 160V A	QEW52CA-335
C1508	PP Cap. 5600uF 50V J	QFP31HJ-562
△C1512	△PP Cap. 2000pF DC1500V J	QFZ0082-202
△C1513	△PP Cap. 2000pF DC1500V J	QFZ0082-202
△C1514	△PP Cap. 2000pF DC1500V J	QFZ0082-202
C1515	PP Cap. 0.53uF DC1200V J	QFZ0067-534
C1520	BPE Cap. 3.3uF 50V A	QEN61HA-335Z
C1523	E Cap. 1uF 160V A	QEW62CA-105Z
C1524	M Cap. 0.1uF 200V K	QFM720K-104M
△C1531	△PP Cap. 2000pF DC1500V J	QFZ0082-202
△C1532	△PP Cap. 1500pF DC1500V J	QFZ0082-152
C1904	E Cap.	QEY0034-001
C1905	E Cap. 10uF 250V A	QEW52EA-106

# NOTES

This space is provided for personal notes

Coils Symbol	Description	Part Number
L1502	Linarity Coil	A39835
L1503	Width Coil	C30380-A
L1504	Heater Choke	C30445-A
Transformers Symbol	Description	Part Number
T1501	Hor. Drive Transf.	A46022-BM
T1503	Side Pin Transf.	C39050-A
Semiconductors Symbol	Description	Part Number
IC1501	IC	HA11244
X1101	Si. Transistor	2SC1685(R)
X1102	Si. Transistor	2SA673(C)
X1103	Si. Transistor	2SC1685(R)
X1104	Si. Transistor	2SA673(C)
X1105	Si. Transistor	2SC1685(R)
X1106	Si. Transistor	2SA673(C)
X1301	Si. Transistor	2SC1685(R)
X1302	Si. Transistor	2SC1685(R)
X1303	Si. Transistor	2SA673(C)
X1304	Si. Transistor	2SC1685(R)
X1305	Si. Transistor	2SC1685(R)
X1401	Si. Transistor	2SD478
X1402	Si. Transistor	2SD478
X1501	Si. Transistor	2SC2610BK
X1901	Si. Transistor	2SC2688 (K.L.M.)
X1902	Si. Transistor	2SC1890A (E.F.)
D1101	Si. Diode	W06A
D1102	Si. Diode	W06A
D1103	Si. Diode	W06A
D1301	Si. Diode	1SZ473H
D1401	Si. Diode	1SZ473H
D1402	Zener Diode	RD10F(C)
D1503	Si. Diode	HF-1
D1504	Si. Diode	V09E
D1505	Zener Diode	RD11E(B)
D1506	Si. Diode	W06A
D1507	Si. Diode	1SS81
D1508	Si. Diode	1SZ473H
△D1701	△Zener Diode	RD20EV2
△D1901	△Si. Diode	1S1887A
△D1902	△Si. Diode	1S1887A
△D1903	△Si. Diode	1S1887A
△D1904	△Si. Diode	1S1887A
△D1905	△Zener Diode	RD6.8EV3
Miscellaneous Symbol	Description	Part Number
△F1901	△Fuse 1.25A	QMF53U1-1R25S
△F1902	△UL Fuse 3A	QMF66U1-3R0S

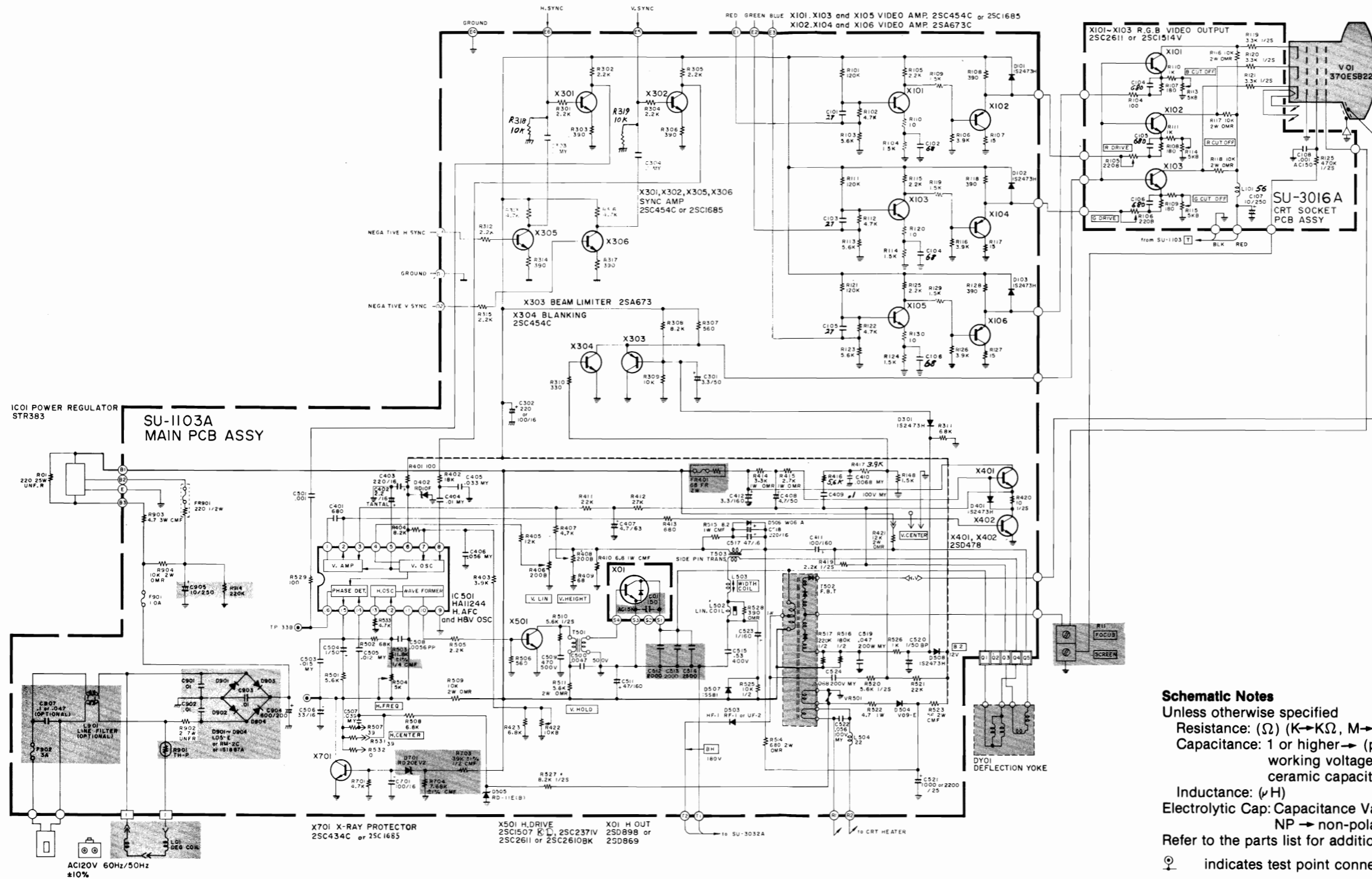

**Schematic Notes**

Unless otherwise specified

Resistance: (Ω) (K→KΩ, M→MΩ), 1/4 (W) carbon resistor  
 Capacitance: 1 or higher→ (pF), less than 1→ (μF)  
 working voltage → 50 (V)  
 ceramic capacitor

Inductance: (μH)

Electrolytic Cap: Capacitance Value (μF)/working voltage (V),  
 NP → non-polar (or bipolar) electrolytic cap.

Refer to the parts list for additional component information.

⊙ indicates test point connection

⊕ indicates chassis ground unless otherwise specified

Hz indicates cycles per second

For **safety** purposes (and continuing reliability)

⚠ replace all components marked with safety symbol with identical type.

NOTE: FR → fusible resistor (⊕—⊕)

Parts identification on circuit boards:

e.g. SU1126A (R107 = R1107)

SU3030A (R113 = R3113)

G07-FBO

00-4147-03

# REPLACEMENT PARTS LIST - ELECTROHOME 13" MONITOR

Components identified by the  $\Delta$  symbol in the PARTS LIST and on the Schematic have special characteristics important to safety.

DO NOT degrade the safety of the set through improper servicing.

## Abbreviations for Resistors and Capacitors

### Resistor

C R	: Carbon Resistor
Comp. R	: Composition Resistor
OM R	: Oxide Metal Film Resistor
V R	: Variable Resistor
MF R	: Metal Film Resistor
CMF R	: Coating Metal Film Resistor
UNF R	: Nonflammable Resistor
F R	: Fusible Resistor

### Capacitor

C Cap.	: Ceramic Capacitor
M Cap	: Mylar Capacitor
E Cap.	: Electrolytic Capacitor
BP E Cap.	: Bi-Polar (or Non-Polar) Electrolytic Capacitor
MM Cap.	: Metalized Mylar Capacitor
PP Cap.	: Polypropylene Capacitor
MPP Cap.	: Metalized PP Capacitor
PS Cap	: Polystyrol Capacitor
Tan. Cap.	: Tantal Capacitor

NOTE: When ordering replacement parts please specify the part number as shown in this list including part name, and model number. Complete information will help expedite the order.

Use of substitute replacement parts which do not have the same safety characteristics as specified, may create shock, fire or other hazards. For maximum reliability and performance, all parts should be replaced by those having identical specifications.

Symbol	Description	Part Number
	Main P.C.B. Ass'y	SU-1103A
	CRT Socket P.C.B. Ass'y	SU-3016A

### Outside of the P.C.B. Ass'y

Symbol	Description	Part Number
$\Delta$ V01	$\Delta$ Picture Tube	370ESB22(E)
$\Delta$ DY01	$\Delta$ Deflection Yoke	C29123-V
	PC Magnet	A76366-A
	Wedge	C30006
	$\Delta$ Flyback Transf.	A19183-A
$\Delta$ R11	$\Delta$ Focus V R	A46606-A
$\Delta$ R05	UNF Resistor 220 $\Omega$ , 25W. K	QRF258K-221
$\Delta$ C04	$\Delta$ C Capacitor 150 pF, AC1.5KV	QCZ0101-005
X01	Si. Transistor	2SD869
IC01	IC Regulator	STR383
L01	Degaussing Coil	21-1007-31
	Degaussing Coil Pin Terminal (2)	34-708-01
	Degaussing Coil Pin Terminal Housing	34-709-01
	Groundstrap Ass'y.	34-697-04
	Groundstrap Wire Terminal	34-228-03
	Groundstrap Spring (2)	35-3560-01
BR	Support Bracket RH	35-3919-01
BR	Support Bracket LH	35-3919-02
SC	SCREW 10- $\frac{1}{2}$ Pix Tube Mtg. (4)	31-631018-08
WA	Pyramidal Lockwasher (4)	33-255-01
	Clip P.C.B. Support (2)	33-629-02
	Ground Lug	34-33-04
CH	Chassis Base	38-452-01

## Main P.C.B. Ass'y (SU-1103A) Parts List

### Resistors

Symbol	Description	Part Number
R1406	V R 200 $\Omega$	QVZ3230-022
R1408	V R 200 $\Omega$	QVZ3230-022
R1410	CMF R 6.8 $\Omega$ 1W J	QRX019J-6R8
R1414	OM R 3.3K $\Omega$ 1W J	QRG019J-332
R1415	OM R 2.7K $\Omega$ 1W J	QRG019J-272
R1421	OM R 12K $\Omega$ 2W J	QRG029J-123
R1422	V R 10K $\Omega$	QVZ3224-014H
$\Delta$ FR1401	$\Delta$ F R 68 $\Omega$ 2W K	QRH024K-680M
$\Delta$ R1503	$\Delta$ CMF R 11.8K $\Omega$ 1/4W +1%	QRV142F-1182
R1504	V R 5K $\Omega$	QVZ3230-053
R1509	OM R 10K $\Omega$ 2W J	QRG029J-103
R1511	OM R 5.6K $\Omega$ 2W J	QRG029J-562
R1514	OM R 680 $\Omega$ 2W J	QRG029J-681
R1515	CMF R 8.2 $\Omega$ 1W J	QRX019J-8R2
R1522	CMF R 4.7 $\Omega$ 1W J	QRX019J-4R7
R1523	OM R 56 $\Omega$ 2W J	ORG029J-560
R1528	OM R 390 $\Omega$ 1W J	ORG019J-391
R1534	ZN R	ERZ-C05ZK471
VR1501	ZN R	ERZ-C05DK271
$\Delta$ R1703	$\Delta$ CMF R 39K $\Omega$ 1/2W +1%	QRV122F-3902
$\Delta$ R1704	$\Delta$ CMF R 7.68K $\Omega$ 1/4W +1%	QRV142F-7681
$\Delta$ R1901	$\Delta$ Posistor	A75414
R1902	UNF R 2 $\Omega$ 7W K	QRF076K-2R0
R1903	CMF R 5.6 $\Omega$ 3W J	QRX039J-5R6
R1904	OM R 10K $\Omega$ 2W J	QRG026J-103Z
$\Delta$ FR1901	$\Delta$ F R 220 $\Omega$ 1/2W K	QRH124K-221M

### Capacitors

Symbol	Description	Part Number
C1402	Tan. Cap. 2.2 $\mu$ F 16V K	QEE51CK-225B
C1411	E Cap. 100 $\mu$ F 160V A	QEW52CA-107
C1412	E Cap. 3.3 $\mu$ F 160V A	QEW52CA-335
C1508	PP Cap. 5600pF 50V J	QFP31HJ-562
C1511	E Cap. 47 $\mu$ F 160V A	QEW52CA-476S
$\Delta$ C1512	$\Delta$ PP Cap. 2000pF DC1500V J	QFZ0082-202
$\Delta$ C1513	$\Delta$ PP Cap. 2000pF DC1500V J	QFZ0082-202
$\Delta$ C1514	$\Delta$ PP Cap. 2500pF DC1500V J	QFZ0082-252
C1515	PP Cap. 0.53 $\mu$ F DC1200V K	QFZ0067-534
C1520	BPE Cap. 1 $\mu$ F 50V A	QEN61HA-105Z
C1524	M Cap. 0.1 $\mu$ F 200V K	QFM72DK-682M
C1904	E Cap.	QEY0034-001
C1905	E Cap. 10 $\mu$ F 250V A	QEW52EA-106
$\Delta$ C1907	$\Delta$ MM Cap. 0.1 $\mu$ F AC150V Z	QFZ9008-104

### Coils

Symbol	Description	Part Number
L1501	Peaking Coil	A75360-6
L1502	Liniarty Coil	A39934
L1503	Width Coil	C30380-A
L1504	Heater Choke	C30333-A
L1901	Line Filter	A39475-J

### Transformers

Symbol	Description	Part Number
T1501	Hor. Drive Transf.	A46022-BM
T1503	Side Pin Transf.	C39050-A



<b>Semiconductors</b>		
<b>Symbol</b>	<b>Description</b>	<b>Part Number</b>
IC1501	I.C.	HA11244
X1101	Si. Transistor	2SC1685(R)
X1102	Si. Transistor	2SA673(C)
X1103	Si. Transistor	2SC1685(R)
X1104	Si. Transistor	2SA673(C)
X1105	Si. Transistor	2SC1685(R)
X1106	Si. Transistor	2SA673(C)
X1301	Si. Transistor	2SC1685(R)
X1302	Si. Transistor	2SC1685(R)
X1303	Si. Transistor	2SA673(C)
X1304	Si. Transistor	2SC1685(R)
X1305	Si. Transistor	2SC1685(R)
X1401	Si. Transistor	2SD478
X1402	Si. Transistor	2SD478
X1501	Si. Transistor	2SC2610BK
X1701	Si. Transistor	2SC1685(P-S)
D1101	Si. Diode	W06A
D1102	Si. Diode	W06A
D1103	Si. Diode	W06A
D1301	Si. Diode	1S2473H
D1401	Si. Diode	1S2473H
D1402	Zener Diode	RD10F(C)
D1503	Si. Diode	HF-1
D1504	Si. Diode	V09E
D1505	Zener Diode	RD11E(B)
D1506	Si. Diode	W06A
D1507	Si. Diode	1SS81
D1508	Si. Diode	1S2473H
△D1701	△Zener Diode	RD20EV2
△D1901	△Si. Diode	1S1887A
△D1902	△Si. Diode	1S1887A
△D1903	△Si. Diode	1S1887A
△D1904	△Si. Diode	1S1887A
<b>Miscellaneous</b>		
<b>Symbol</b>	<b>Description</b>	<b>Part Number</b>
△F1901	△Fuse 1A	QMF53U1-1R0S
△F1902	△UL Fuse 3A	QMF66U1-3R0S

## CRT Socket P.C.B. Ass'y (SU-3016A) Parts List

### Resistors

Symbol	Description	Part Number
R3105	V R 200 $\Omega$	QVZ3234-022
R3106	V R 200 $\Omega$	QVZ3234-022
R3113	V R 5K $\Omega$	QVZ3234-053
R3114	V R 5K $\Omega$	QVZ3234-053
R3115	V R 5K $\Omega$	QVZ3234-053
R3116	OM R 10K $\Omega$ 2W J	QRG029J-103
R3117	OM R 10K $\Omega$ 2W J	QRG029J-103
R3118	OM R 10K $\Omega$ 2W J	QRG029J-103
R3119	Comp. R 3.3K $\Omega$ ½W K	QRZ0039-332
R3120	Comp. R 3.3K $\Omega$ ½W K	QRZ0039-332
R3121	Comp. R 3.3K $\Omega$ ½W K	QRZ0039-332

### Capacitors

Symbol	Description	Part Number
C3107	E Cap. 10uF 250V A	QEW52EA-106
C3108	C Cap. 1000pF DC1400V P	QCZ9001-102M

### Coils

Symbol	Description	Part Number
L3101	Peaking coil	QQL043K-101

### Semiconductors

Symbol	Description	Part Number
X3101	Si. Transistor	2SC2611
X3102	Si. Transistor	2SC2611
X3103	Si. Transistor	2SC2611

### Miscellaneous

Symbol	Description	Part Number
△	△ CRT Socket	A75522

# INSTALLATION AND SERVICE INSTRUCTIONS

## COLOR PURITY AND VERTICAL CENTERING ADJUSTMENT

For best results, it is recommended that the purity adjustment be made in the final monitor location. If the monitor will be moved, perform this adjustment with it facing west or east. The monitor must have been operating 15 minutes prior to this procedure and the faceplate of the CRT must be at room temperature.

The monitor is equipped with an automatic degaussing circuit. However, if the CRT shadow mask has become excessively magnetized, it may be necessary to degauss it with manual coil. Do not switch the coil OFF while the raster shows any effect from the coil.

Purity Magnets are used for Color Purity and V Centering Adjustment.

Purity Adjustment procedure is as follows.

1. Remove R-G-B signal from monitor.
2. Turn Green Cut off Control (VR404) on the Neck Board fully CCW.  
Turn Red and Blue Cut off Control (VR405) fully CW.
3. Pull the Deflection Yoke backward so that the Magenta belt will appear. (See Fig. 4)
4. Move the two Purity Magnets and bring the Magenta belt to the mechanical center of the screen (See Fig. 5) The vertical center position should be set VRS to  $-5/64$ " ( $-2$  mm) as shown in Fig. 6.  
Insert service tip "N" on Neck circuit board to "S" on Vert./Horiz. circuit board (See Fig. 13). To check, use the Green raster at low intensity. Be sure to return the service tips to their original positions for the next check.
5. Push the Deflection Yoke forward gradually and fix it at the place where the Magenta screen becomes uniform throughout.
6. Turn Cut off Control, and Drive Control and confirm that each color is uniform.
7. If the color is not uniform, re-adjust it moving Purity Magnets slightly.
8. Move a pair of Purity Magnets at the same time (do not change the angle of the pair), and adjust the vert. center to center of screen.
9. Obtain the three colors and confirm whether white uniformity is balanced.
10. Insert the temporary wedge as shown in Fig. 5 and adjust the angle of Deflection Yoke.

## STATIC CONVERGENCE ADJUSTMENT

A recently developed Deflection Yoke and Electron Guns construction has been used on this equipment in combination with In-Line Guns and Black Stripe Screen to make a barrel-type magnetic-field distribution for vertical deflection and a pin-cushion-type magnetic field for horizontal deflection with which a self-converging system can be obtained. This type is different from conventional unity-magnetic field distribution type deflection yoke. 4-Pole Magnets and 6-Pole Magnets are

employed for static convergence instead of a Convergence Yoke.

1. A cross hatch signal should be connected to the monitor.
2. A pair of 4-Pole Convergence Magnets are provided and adjusted to converge the blue and red beams. When the Pole opens to the left and right  $45^\circ$  symmetrically, the magnetic field maximizes. Red and blue beams move to the left and right oppositely (See Fig. 7-a and 7-b). Variation of the angle between the tabs adjusts the convergence of red and blue vertical lines.

When the both 4-Pole Convergence Magnet Tabs are rotated as a pair, the convergence of the red and blue horizontal lines is adjusted.

3. A pair of 6-Pole Convergence Magnets are also provided and adjusted to converge the magenta (red + blue) to green beams.

When the Pole opens to the left and right  $30^\circ$  symmetrically, the magnetic field is maximized. Red and blue beams both move to the left and right (See Fig. 8-c and 8-d).

Variation of the opening angle adjusts the convergence of magenta to green vertical lines. When both 6-Pole Convergence Magnet Tabs are rotated as a pair the convergence of magenta to green horizontal lines is adjusted.

## PRECISE ADJUSTMENT OF DYNAMIC CONVERGENCE (See Fig. 10 and 11)

1. Feed a cross hatch signal to the monitor.
2. Insert the temporary wedge and fix Deflection Yoke so as to obtain the best circumference convergence (See Fig. 10 and 11).

NOTE:

The temporary wedges may need to be moved during adjustments.

4. Insert three rubber wedges to the position as shown in Fig. 9 to obtain the best circumference convergence.

NOTE:

- 1) Tilting the angle of the yoke up and down adjusts the crossover of both vertical and horizontal red and blue lines. See Fig. 10 (a) and (b).
- 2) Tilting the angle of the yoke sideways adjusts the parallel convergence of both horizontal and vertical lines at the edges of the screen. See Fig. 11-a and b.
- 3) Use three rubber wedges (thick and thin rubber wedges are used for a purpose).
- 4) The angle of each rubber wedges are shown in Fig. 9.
- 5) After three rubber wedges have been inserted, pull out the temporary wedge.
- 6) Fix the rubber wedges with chloroprene rubber adhesive.

# INSTALLATION AND SERVICE INSTRUCTIONS

## BLACK AND WHITE TRACKING (With R/G.B. inputs grounded)

1. Set Black Level Control (VR201) to mid point.
2. Set Red and Blue Drive Controls (VR401 & VR402) to their mechanical center.
3. Set the G2 Screen Control (VR406) and the 3 Cut-off Controls (VR403, VR404, & VR405) to minimum

(CCW).

4. Slowly turn up G2 screen control until the first faint color appears.
5. Slowly turn up the other two color cut-off controls in turn to match the first.
6. Remove ground from R/G/B/ inputs. Adjust Red and Blue Drive Controls (VR401 & VR402) for white screen.

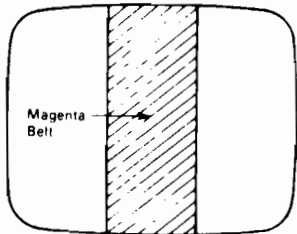

FIGURE 4

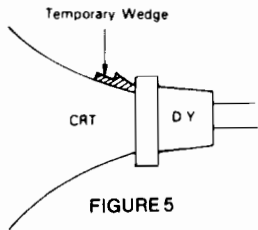
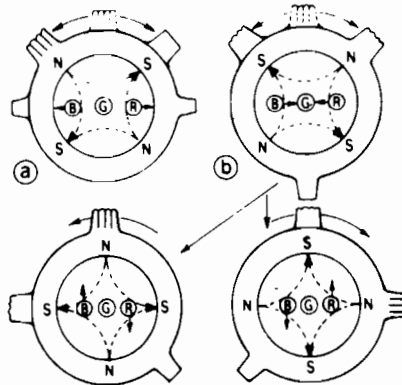

FIGURE 5

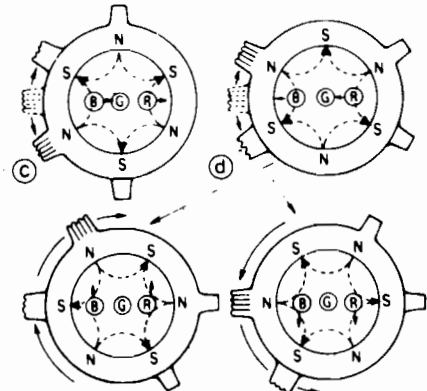

FIGURE 6



4-Pole Magnets and the Movement of Beams

FIGURE 7



6-Pole Magnets and the Movement of Beams

FIGURE 8

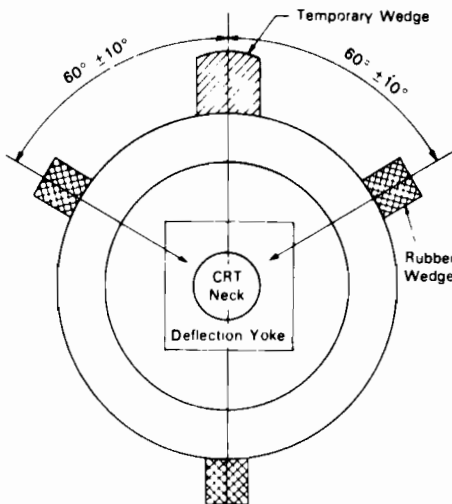
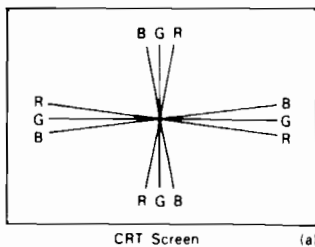
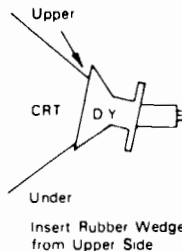

FIGURE 9



CRT Screen (a)



Insert Rubber Wedge from Upper Side

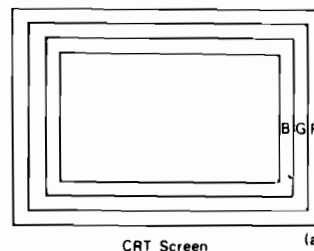

CRT Screen (a)

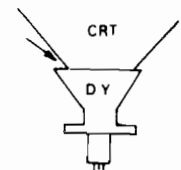

Insert Rubber Wedge from Left Side

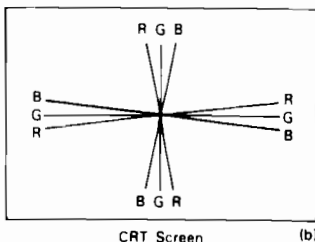

CRT Screen (b)

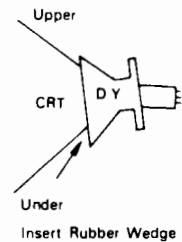

Insert Rubber Wedge from Lower Side

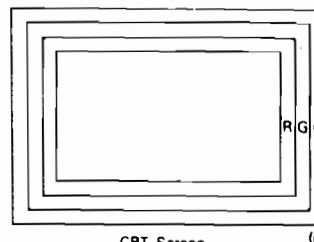

CRT Screen (b)

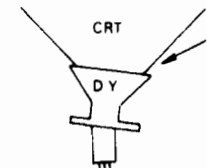

Insert Rubber Wedge from Lower Side

FIGURE 11

# MONITOR - GENERAL INSTRUCTIONS

## Service Set-Up Procedure

**NOTE:** All monitors are equipped with automatic degaussing coils which effectively demagnetize the picture tube each time the monitor is turned on. The degaussing coils will operate any time the set is turned on after having been off for at least five minutes.

The degaussing effect is confined to the picture tube since the coils are mounted on the ferrous tube shield. Should any part of the chassis or cabinet become magnetized, it will be necessary to degauss the affected area by means of a manual degaussing coil. Move the coil slowly around the CRT face area, then slowly withdraw for a distance of six feet before disconnecting the coil from the AC power supply.

Normally little, if any adjustment should be necessary. However, when a picture tube, yoke or similar component is replaced, preliminary static convergence should be done before attempting purity adjustment, and so on.

Set up should be done in a north/south direction. Horizontal and vertical centering taps should be set to the centre position if a major component has been changed.

### 1.0 Purity

- 1.1 Loosen yoke retaining clamp (figure 2), remove adhesive material fixing wedges to CRT. Remove wedges completely and clean off dried adhesive from picture tube and wedges.
- 1.2 A small quantity of "nail polish" has been used to lock the purity convergence rings in place. This seal must be broken with a sharp tipped instrument before any adjustments are attempted. Some models also use a locking ring at either end of the purity and convergence rings. This must be loosened before adjustments are made. It goes without saying that upon completion of all adjustments, the lock must be reset and/or a dab of paint or nail polish must be re-applied to edge of rings to prevent movement.
- 1.3 Connect an appropriate signal source, eg: Electro-home RGB generator producing a white field plus individual red, green and blue fields.
- 1.4 Bring the long and short purity tab protrusions in line with each other to obtain near-zero magnetic field (figure 4) (In some cases bring the flat and indented tabs together to obtain zero field). Protrusions can then be vertical, horizontal or at any convenient angle to start.
- 1.5 Turn off the green and blue fields and adjust setup controls to produce a red field. (See fig. 3)
- 1.6 Pull the deflection yoke back so that a red band appears in the centre of the screen.
- 1.7 Spread the tabs apart as little as necessary and rotate both rings together to center the red band horizontally on the face of the CRT (approximate). (See Fig. 5)
- 1.8 Slide the yoke towards the bell of the picture tube slowly to obtain a uniform red field (pure in color) across the entire tube face. Juggle back and forth slightly as necessary. Lightly tighten yoke retaining clamp.
- 1.9 Momentarily switch on a cross-hatch signal and rotate yoke to level the pattern on the face of CRT.
- 1.10 Return generator to regain red raster.
- 1.11 Turn off red field and check for pure field for each of the green and blue fields. Reposition yoke if necessary to obtain optimum purity on all fields.
- 1.12 Tighten yoke retaining clamp to prevent yoke shift or rotation. (Do not install wedges at this time.)

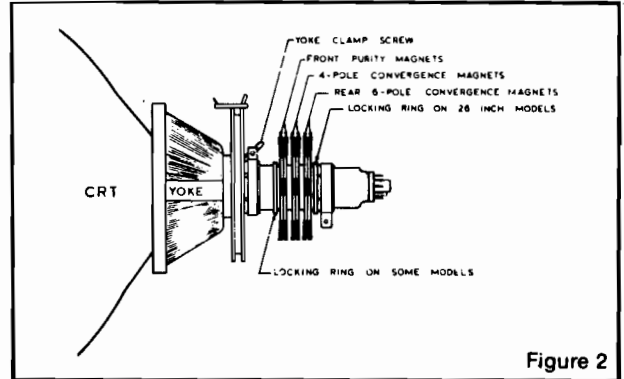

Figure 2

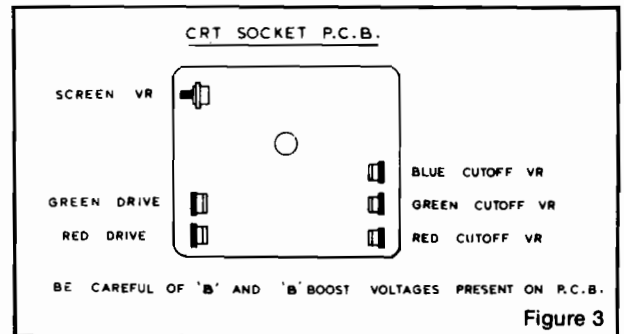

Figure 3

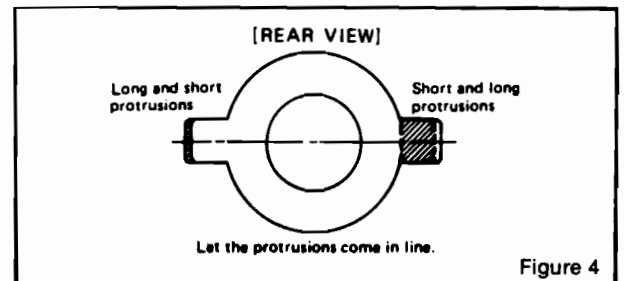

Figure 4

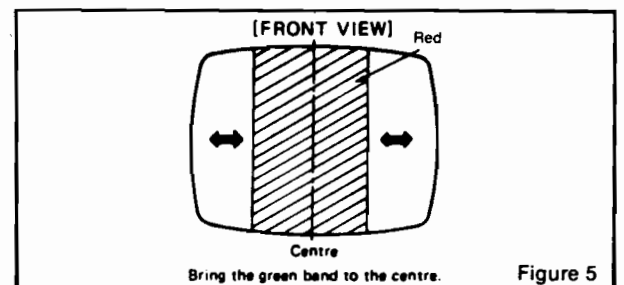

Figure 5

**2.0 Static and Dynamic Convergence**

NOTE: Static convergence is achieved by four magnets located on the neck, nearest the base of the picture tube, Fig. 2. The middle pair of magnetic rings are adjusted to converge the blue and red crosshatch lines. The rear pair of convergence rings (closest to the base of the picture tube) are adjusted to converge the magenta (blue/red) to the green crosshatch lines. Dynamic convergence is achieved by tilting the deflection yoke up-down and left-right.

- 2.1 Ensure that the controls misadjusted during purity setup (screen, cut-off, etc.) are set to give white balance. See 3.0 below.
- 2.2 Switch generator to the crosshatch pattern.
- 2.3 Adjust convergence around the edges of the picture tube by tilting the yoke up-down and left-right, and temporarily install one wedge at the top of the yoke or in a more optimum position. (Figures 8, 9, 10)
- 2.4 Turn off green input and turn on the red and blue input.
- 2.5 Rotate the 4-pole (middle) pair of magnets as a unit to minimize separation of the red and blue crosshatch lines around the center of the screen (Figure 6). Variation of the angle between the tabs adjusts convergence of red and blue. (Tilt yoke as required to converge red and blue at the edges as in 2.3 above.)
- 2.6 Turn on green input to obtain magenta (red/blue) and green crosshatch lines. Rotate the 6-pole (rear) pair of magnets as a unit to minimize separation of the magenta and green lines (figure 7). Vary angle between the two tabs and further rotate as a unit to finalize.
- 2.7 When convergence of 3 colors is optimized (static in center and dynamic around edges) apply stripe of paint or nail polish to convergence magnet rings to prevent movement. If applicable, tighten locking ring carefully.
- 2.8 Remove temporary wedge from yoke. Tilt yoke in up-down and left-right direction for best circumference convergence and install 3 wedges. (It is best to use 3 new wedges since they have adhesive backing. Simply pull off tape, slide wedge in place and press outer flap down firmly. For more permanency apply small quantity of silastic or similar material at junction of wedges and picture tube. Do not disturb while material is setting. (Order wedges by part number 39-1233-01).

**3.0 White Balance (Grey Scale Tracking)**

Refer to figure 3. Do the following in subdued light:

- 3.1 Note this adjustment can be accomplished with no signal connected; eg: input connector open or if a signal generator is connected, switch off all 3 inputs at the generator.
- 3.2 Set red and green drive controls to their mechanical center and turn the common G2 screen control and 3 cut-off controls to minimum (fully counterclockwise).
- 3.3 Slowly turn up G2 screen control until the first faint color appears, then back off to edge of visibility. Do not touch the associated cut-off control - it should stay fully CCW for the remaining set-up.
- 3.4 Slowly turn up the other two color cut-off controls in turn to match the first. This should result in the faintest grey.
- 3.5 Turn on the signal generator with all 3 inputs on. (a crosshatch pattern would be appropriate).

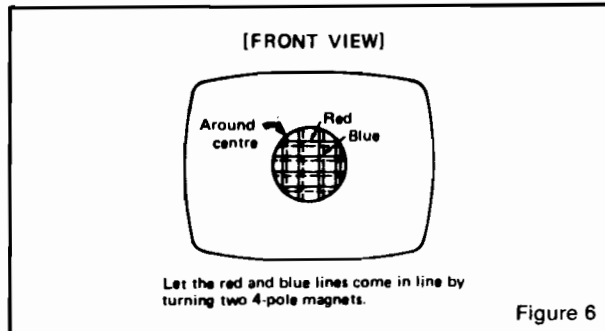

Figure 6

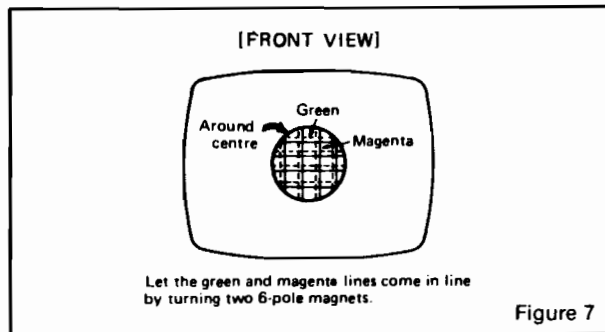

Figure 7

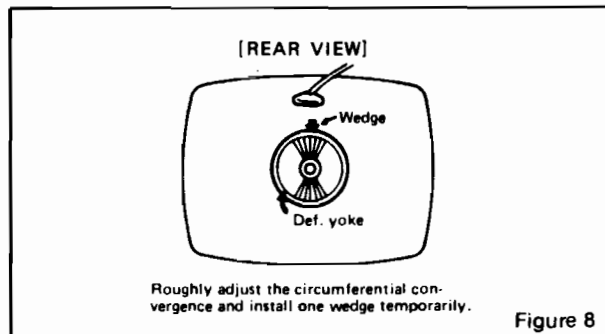

Figure 8

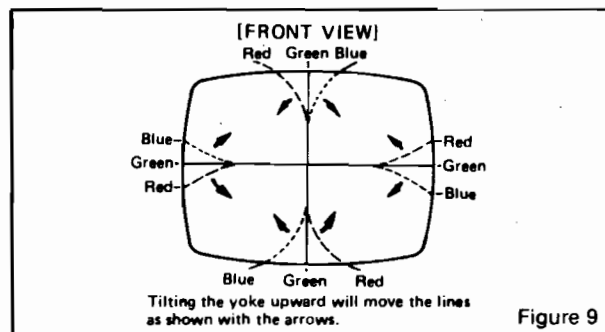

Figure 9

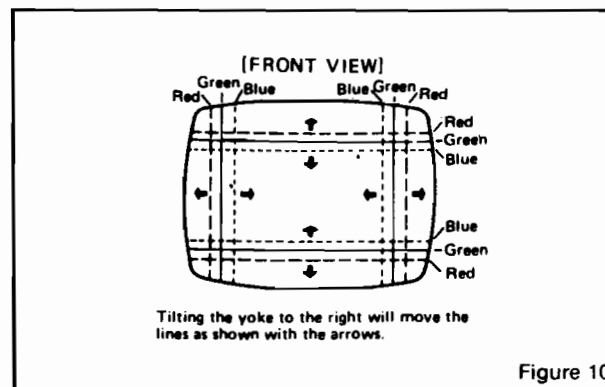

Figure 10

- 3.6 Adjust the red and green drive controls for "neutral white" on high white picture areas. Generally these controls will be left at mech. centre.
- 3.7 Note: When monitor is re-connected with the game the screen control (G2) may require a slight adjustment to obtain proper black level. (the black portion of picture just extinguished).

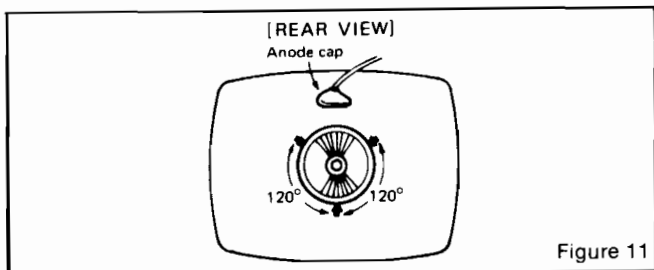

Figure 11

#### 4.0 Power Supply

The regulated +B1 control (R909) has been factory adjusted and normally requires no adjustment. However, if any repairs have been made to the chassis it is recommended that this adjustment should be made.

- a) Allow 5 minutes to warm up.
- b) No signal applied.
- c) Connect an accurate D.C. voltmeter to TP-91 or the emitter of X04 power regulator transistor.
- d) Adjust R909 for 120V. (See fig. 1)

**Note:**

Should +B1 control be set too high, it may cause possible component damage. Use an accurate D.C. voltmeter to set B1 (B+).

#### 5.0 Focus

Adjust focus control for best overall definition and picture detail an average signal applied. (Highlights should be favoured.)

#### 6.0 Color Service Generator for G07 Monitor

Electrohome has developed a color service generator that is specifically designed for use with the G07 color data monitor. It provides the monitor with both horizontal and vertical sync, as well as the following test patterns:

- 1) Fine cross-hatch pattern
- 2) Broad bar cross-hatch pattern
- 3) Complete field

Three color selection switches, red, green and blue, provide the ability to display the above patterns in the three primary colors as well as the three secondary colors.

This product may be ordered from:  
 Contracts Marketing  
 ELECTROHOME Electronics  
 809 Wellington St. North  
 Kitchener, Ontario  
 Canada N2G 4J6  
 Telephone: (519) 744-7111, Ext. 567

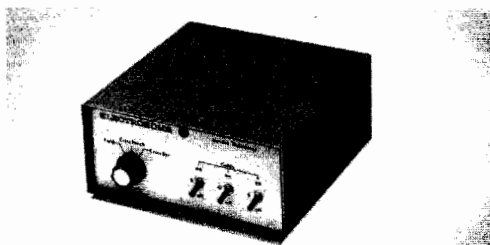

#### 7.0 X-Ray Emission Check

- 7.1 Assure the power supply B1 is properly adjusted to 120V DC. See Item 4.0 (page 8)
- 7.2 Assure that the anode voltage does not exceed max. as per Item 2.0 page 4.
- 7.3 Assure that the high voltage hold down circuit is operating correctly. Use the following procedure.
  - a) Increase the B1 greater than 138.5V by shorting collector/emitter of the power regulator, X04.
  - b) Observe that the anode voltage (EHT) goes to 0. If the EHT does not go to 0, a fault must be located and repaired.
  - c) Remove short and set should return to normal operation. (Note, after the short is removed some monitors may not restart. In this case, remove power from monitor momentarily and normal operation will be restored.

**Note:**

The protector circuit consists of the components shown below in Fig. 13 with a circuit description.

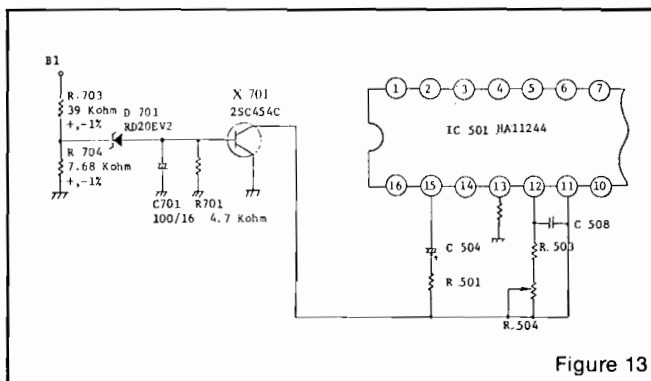

Figure 13

#### 8.0 Circuit Diagram and Description of High Voltage Hold Down or Safety Circuit

- 8.1 Circuit Diagram of High Voltage Hold Down Circuit.
- 8.2 Operation of High Voltage Hold Down Circuit.

The high voltage hold-down circuit protects the high voltage circuit from dangerous voltage with short circuiting between emitter and collector of power regulating transistor.

The base voltage of X701 is increased when the B1 voltage is increased more than 138.5 V DC.

When the base of X701 is increased, a short is produced by X701 between pin 11 and ground of IC 501, shutting down the horizontal osc. and high voltage.

**GORF GAME BOARD****PC A084-90708-A873**

CHIP NUMBER	FUNCTION
74LS04	Hex inverter
74LS30	8 input Nand
74LS74	Dual "D" Flip-Flop
74LS86	Quad 2 input exclusive or
74LS153	Dual 4 to 1 line multiplexer
74LS161	4 bit binary counter
74LS164	8 bit shift register
74LS174	Hex "D" Flip-Flop
74LS257	Quad 2 to 1 line multiplexer - tri-state
74LS367	Hex bus driver - tri-state
0066-117XX (2720)	Custom I/O chip
MC14066	Quad bilateral switch - Cmos
MC14099	8 bit addressable latch - Cmos
MC14539	Dual 4 to 1 line multiplexer - Cmos
SC01	Voice sound generator
Additional Devices	
2N4401	NPN transistor
2N4403	PNP transistor
2N6427	NPN transistor
L1, L2, L3	10 uH choke

**RGB INTERFACE****PC A082-91363-A000**

TBA530	Op-Amp
Additional Devices	
2N4401	NPN transistor

**CONTROL GRIP ASSEMBLY****A082-91379-A000**

LM339	Voltage comparator
Additional Devices	
Spx11879-11	Sensor

**GORF ROM/RAM BOARD****PC A082-91364-A000**

CHIP NUMBER	FUNCTION
74LS02	Quad 2 input Nor
74LS08	Quad 2 input And
74LS30	8 input Nand
74LS32	Quad 2 input Or
74LS74	Dual "D" Flip-Flop
74LS133	13 input Nand
74LS138	3 to 8 line decoder / multiplexer
74LS244	Octal buffer
MC14078	8 input Nor - Cmos
2114	1K x 4 - Ram
9332	4K x 8 - Rom

**CPU BOARD****PC A082-91354-C000**

74LS00	Quad 2 input Nand
74LS02	Quad 2 input Nor
74LS04	Hex inverter
74LS08	Quad 2 input And
74LS10	Triple 3 input Nand
74LS20	Dual 4 input Nand
74LS74	Dual "D" Flip-Flop
74LS157	Quad 2 input multiplexer
74LS174	Hex "D" Flip-Flop
74LS175	Quad "D" Flip-Flop
Z80	CPU
2719-(0066-115)	Address custom chip
2721-(0066-116)	Data custom chip
74LS245	Octal bus transceiver
74LS257	Quad 2 input multiplexer
74LS74	Dual "D" Flip-Flop
7416	Hex buffer
MC14024	7 stage ripple counter
Additional Devices	
2N4401	NPN transistor
T1S-137	PNP transistor
IN4004	Diode
IN4148	Diode
14.31818	Crystal



**PATTERN BOARD**  
**PC A082-91355-C000**

CHIP NUMBER	FUNCTION
74LS00	Quad 2 input Nand
74LS04	Hex inverter
74LS74	Dual "D" Flip-Flop
74LS157	Quad 2 input multiplexer
74LS161	4 bit binary counter
74LS175	Quad "D" Flip-Flop
74LS257	Quad 2 input multiplexer
74LS367	Hex bus driver
CD4555	Dual binary 1 or 4 decoder
MC14008	4 bit full adder
MC14013	Dual "D" Flip-Flop
MC14068	8 input Nand
MC14174	Hex "D" Flip-Flop
MC14175	Quad "D" Flip-Flop
MC14516	Binary up/down counter
MC14539	Dual 4 input multiplexer
MC14572	Multiple gate package

**RAM BOARD**  
**PC 082-91356-C000**

74LS08	Quad 2 input And
74LS14	Hex schmitt trigger
74LS166	Parallel to serial shift register
74LS253	Dual 4 input multiplexer
MK4027 (MK4015)	RAM

**AUDIO AMPLIFIER BOARD**  
**PC A082-90903-A000**

2N4403	PNP transistor
TIP 31	NPN transistor
IN4004	Diode

**POWER SUPPLY**  
**PC A082-90411-A000**

LM317	Voltage regulator
LM339	Quad voltage comparator
SG3532	General purpose regulator
Additional Devices	
79M05	Negative five voltage regulator
IN3235	Zener diode
2N3055	NPN transistor

NOTE: When an IC is a LS, it should be replaced by a LS device (low schottky).

## STRAPPING CHART

### ROM / RAM BOARD

#### DOMESTIC FOR ROMS

	1	2	3	4	5	6	7	8	9
X-31	CLOSED	OPEN	OPEN	OPEN	CLOSED	OPEN	CLOSED	CLOSED	OPEN
X-32									
X-33	CLOSED	OPEN	CLOSED	OPEN	OPEN	CLOSED	CLOSED	OPEN	

#### DOMESTIC FOR PROMS

	1	2	3	4	5	6	7	8	9
X-31	CLOSED	OPEN	CLOSED	OPEN	OPEN	OPEN	CLOSED	CLOSED	OPEN
X-32									
X-33	CLOSED	OPEN	CLOSED	OPEN	OPEN	CLOSED	CLOSED	OPEN	

#### FOREIGN ROMS

	1	2	3	4	5	6	7	8	9
X-31	CLOSED	OPEN	CLOSED	OPEN	OPEN	CLOSED	OPEN	CLOSED	OPEN
X-32	CLOSED	OPEN	OPEN	OPEN	CLOSED	CLOSED	OPEN	CLOSED	OPEN
X-33	CLOSED	OPEN	CLOSED	OPEN	OPEN	CLOSED	CLOSED	OPEN	

#### RAM/ROM BOARD

CUT	JUMPER	JU 20	FOR	74LS241	LOCATION	U15
* CUT	JUMPER	JU 21	FOR	74LS244	LOCATION	U15
CUT	JUMPER	JU 22	FOR	74LS32	LOCATIONS	U2, U3, U4, U5
* CUT	JUMPER	JU 23	FOR	74LS08	LOCATIONS	U2, U3, U4, U5

#### GORF GAME BOARD

CUT	JUMPER	JU 2	FOR	VOCAL SOUND
	JUMPER	JU 1	IN	FOR COCKTAIL
	JUMPER	JU 1	OUT	FOR UPRIGHT