

FRUITION is upon us. That is, things are beginning to come together. There is an ad in this issue for real expansion of the Arcade, by the availability of PROJECT FOUR, now termed the BLUE RAM. PROJECT ONE is still on schedule, with printed circuit boards due the end of June. More 'things' will be coming as experimenters develop usages for their surplus boards.

RF MODULATORS are almost gone. I only found 30 of them, and have a couple left. If interested, give me a call.

PROJECT FOR CONSIDERATION Take one of these salvage boards and convert it into some home usage application where it is not necessary to use the keypad or TV screen except for initial set-up or occasional use later. If the board was set up to monitor a water level sensor in the basement and then turn on the sump pump ( amongst a lot of other similar-type operations) you wouldn't need the screen or RF modulator unless you wanted to change the program. The salvage board could evolve into the home-control computer we keep reading about.

MUSIC IN PRINT and other goodies. The June issue of CREATIVE COMPUTING has a number of interesting articles.

A large portion of the magazine is devoted to music generation and reproduction, both phonograph and computer. Some would complement the material that was provided last issue. In addition, there is an article on the new Apple music synthesizer (ALF) that seems to be what Bally was going to do with their still-born MUSIC videocade. (Show a staff on the screen and input notes directly from the hand controller.)

Another article discusses the methods used to produce kaleidoscope effects on the screen, which the Bally has in the SCRIBBLING game when in the  $\emptyset$  player mode.

Then there is an article on the full-sized arcade game of SPACE INVADERS by Bally.

And last, but certainly not least, there is a paragraph on TIM HAYS, the clever young programmer of SEEREE's with a photo of him at the SF Computer Faire.

SOURCE has been mentioned here before. This is an electronic mail, bulletin board, information service, computer service, etc., utilizing a large computer and the telephone lines to connect them all together. Through this system, two home computers can talk to each other, regardless of type. I recently subscribed, using my APPLE II as the terminal here. There is a plan afoot to enable the Bally to use the telephone lines via a suitable device - more when available. At any rate, I'm at TCD959, and if you are interested, I can get a reduced initiation fee.

COMPUTER FEST AND FLEA MARKET held here at the Fair Grounds was fairly well attended. The quantity of people there surged up and down with a definite drop-off at noon. About 2:30 or so, most of the 'stuff' was gone, so I guess it was an overall success. Vendors were primarily stores (Jade, Godbout), then small businesses, individuals with a board to sell, then flea market stuff, then a few odd-balls like myself primarily there to meet people with like interests. About a dozen local ARCADIAN subscribers stopped by to visit with Dick Houser and myself. All the kids had a good time playing Artillery Duel and O-Jello which we had up and running. I also had a production sample of the BLUE RAM to show people, and to describe some of its features.

BLUE RAM SUPPORT Once this gets off the ground, we will be working on means to support it. This could run from programs utilizing the machine language capability, to power control devices that are activated by the I/O ports, to a different plug-in cartridge to replace Bally Basic, to ???

WIRING We now have a list of about two dozen persons interested in wiring up kits on a fee basis. These people are being contacted, and I expect that fully-wired BLUE-RAMs will be available about a month from now.

~~Revis "ATTACK" change line 5 to 50 X-X+2-K, Y-Y+2-J No~~

See 2-88

IT'S  
ARRIVED

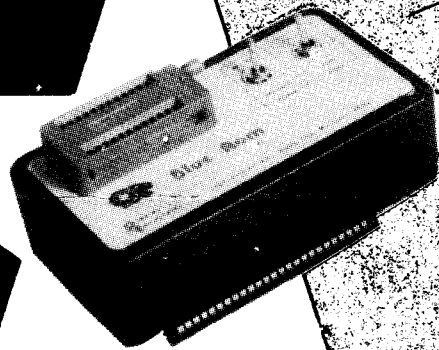

a  
star  
is born!

PROJECT 4

## Blue Ram mini ADD-ON

for your BALLY ARCADE with Basic

- EXTENDED STRINGS (2112 additional entries)
- MACHINE LANGUAGE PROGRAMMING  
(Up to 4K programs run w/wo BASIC)
- MODIFY / SAVE GAME CASSETTES on TAPE
- HOOK UP TO THE REAL WORLD  
(TWO 8bit bi-directional I/O ports)
- COMPLETE WITH DIAGNOSTIC & UTILITY  
PROGRAMS (for multi-color graphics and  
complex sound effects)

**\$130<sup>00</sup>**  
KIT

**\$170<sup>00</sup>**  
WIRED Allow  
2-4wks



Blue Ram

PERKINS  
ENGINEERING

1004 Pleasant Ave. Boyne City, Michigan 49712

## Coming Attractions . . .

ADDITIONAL LOW-COST  
APPLICATION KITS\*

(Available soon)

- TYPEWRITER KEYBOARD
- MODEM
- LIGHT-PEN
- LAMP/MOTOR CONTROL
- MULTI-SENSOR INPUT

\*Plugins for Blue Ram

Sixty - eight



SCHEMATIC DIAGRAMS are included for a number of items. These are primarily as-received; that is, I haven't had a chance to check them out. I would appreciate any feedback you may have on these circuits, and if one or another of you are able to produce them commercially, lets hear the word.

KEYBOARD ATTACHMENT. In the last issue of 1979, Tom Wood reviewed two schemes for installing a keyboard. As it has developed, the more practical way was by inputting data through the cassette interface (using a :INPUT command) that had been originated by Ed Mulholland. Hank Chiuppi has done some more work on this scheme, and the results follow. Again, this is a schematic, not a wiring diagram - you have to use some imagination to make this operate. The keyboard is the JAMECO 610 kit (79.95 plus post) 1355 Shoreway Rd. Belmont CA 94002. It has full ASCII encoding, and contains a 16pin DIP connector. A cable from this connector to a circuit board that has the UART on it is needed, and then a cable to the cassette interface. Three spst switches are needed here (or a single 3pst - pushbutton might work) as well as some wiring additions. The switches allow you to disconnect the keyboard when you need the cassette operation.

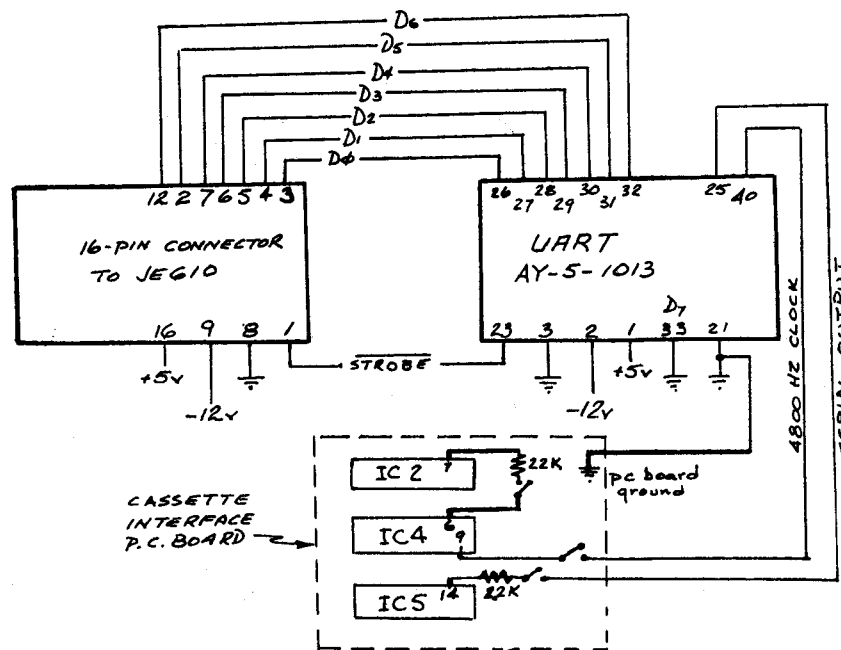

```

3  1 .
   2 .
   3 .
   4 .SPIRALS
   5 .BY MATT GIWER
   6 NT=0
  10 CLEAR
 100 A=3
 200 B=RND (2)
 210 C=RND (2)
 800 X=B;Y=0
 810 LINE X,Y,4
 850 FOR D=1TO 100
 900 X=X+B
 905 Y=Y+C
 907 IF X>75GOTO 100
 908 IF Y>35GOTO 100
 910 GOSUB 1050
 950 NEXT D
 990 GOTO 100
1050 .M
1060 LINE X,Y,A
1070 LINE X,-Y,A
1090 LINE -X,-Y,A
1100 LINE -X,Y,A
1200 RETURN
9000 .M
>

```



TUTORIAL -Serial and Parallel

A computer moves data in one of two ways; serial, or one at a time; and parallel, where groups of data are moved. Most things in the world happen in a serial fashion - cars passing a toll booth, seconds of time, this typewriter putting one letter at a time on paper, etc. Inside the computer, a "word" always has some kind of starting symbol, and some kind of ending symbol. If it were a number, the starting symbol might be the sign, either + or -. Or something more abstract. Certainly has to be consistent. The length of the word is not too important as long as the symbols are there to tell its length. In a parallel system, the data is lumped into groups, say eight units per group. It is all sent at once, on eight lines. The same kind of data always shows up in the same spot within the group of eight. The sixth piece of data might be the decimal point, for example, for data that is always dollars and cents.

There are devices to transfer one kind of transmission into the other. One familiar serial - to - parallel transfer device is the adding machine - the kind with a paper tape. You punch in the numbers one after another, when the machine prints them, all the digits appear at once. The adding machine stored the serial data until it was told to output it, so it has some sort of memory. Bally output is serial, so we need devices that accept serial data. The Comprint printer I use does this directly - it includes a memory device to store the data, even though it prints it serially because it waits for a carriage return before it prints the whole line. The Comprint also comes as a parallel machine (at \$30 less cost, \$495 FOB here) to match up with computers that have parallel outputs (like the APPLE). Included herein is a wiring schematic that will allow the use of a parallel printer with the Bally serial output. Designed by Rich Tietjens, he reports that it has operated with the Heath, Centronics, Base 2 machines.

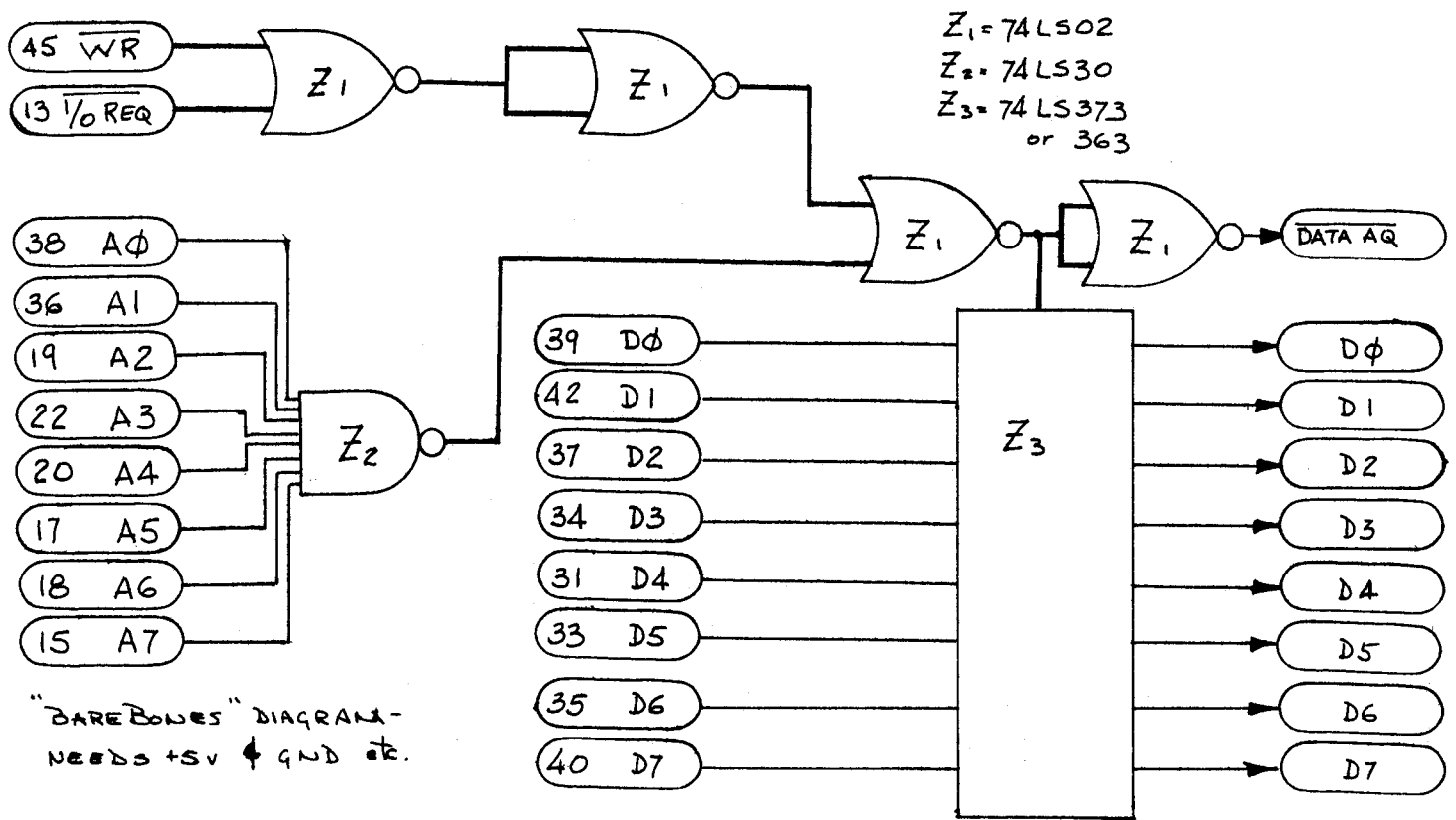

"BARE BONES" DIAGRAM - NEEDS +5V & GND etc.

# ARCADIAN

TV TAPE RECORDER HOOKUP is shown for those who may be interested in seeing how I do it. The Bally and its TV set are in my workshop, as is the RCA recorder. I use one of the otherwise unused TV channel inputs for the Bally when recording, tuned to channel 3 so that I can tape the Bally display off the screen. This technique was used to make up a special tape showing "things you can do with the Bally" that I had at the computer show. In order to let the family watch the recorder for things they are interested in, I've put in an RF switch similar to those used by cable TV subscribers, at the machine to allow the output of the recorder to enter the master antenna circuit through a signal splitter that is hooked up backwards. (two into one)

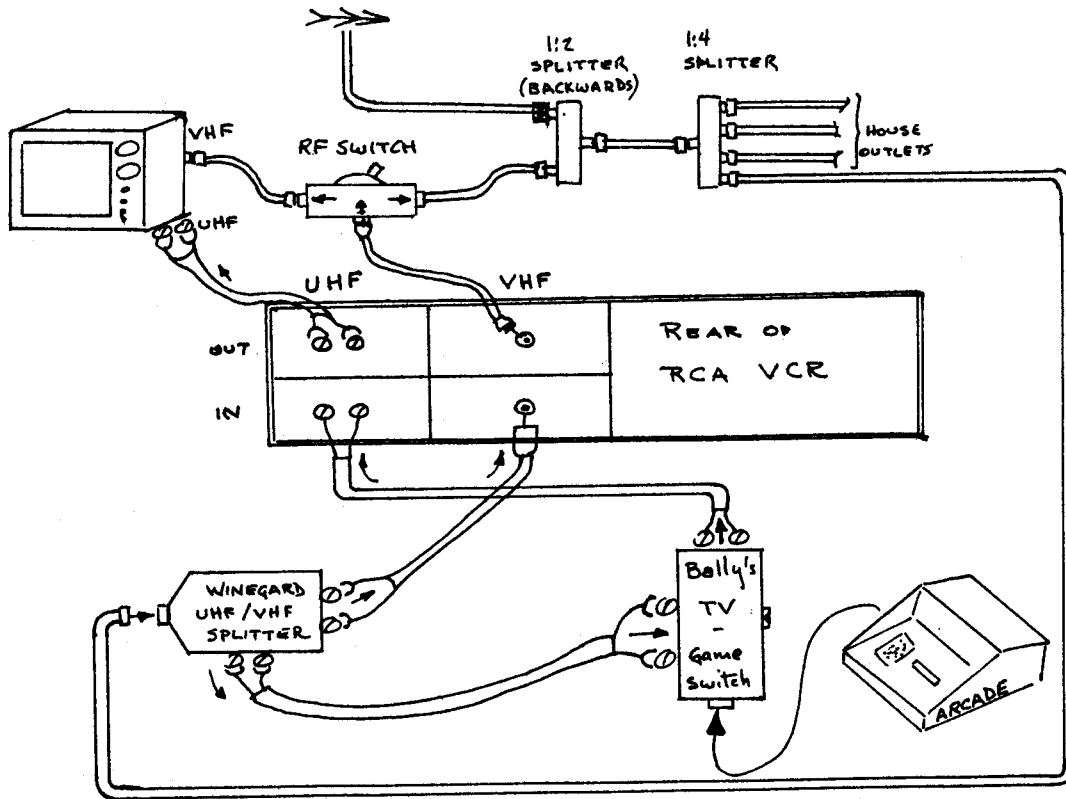

CASSETTE INTERFACE MODIFICATION is being factored into the production line at Bally. This mod will reduce the number of ??? you get when swapping tape between recorders. It increases reliability and compatibility between machines, and is a simple revision.

OLD:

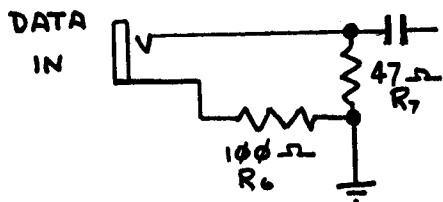

NEW:

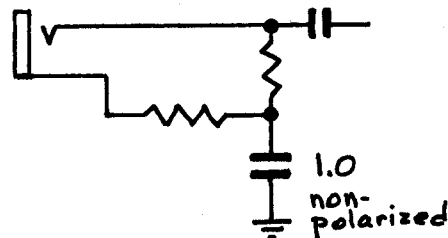

[could be  $\frac{1}{2}$  1.0 tantalum]

# ARCADIAN

```

3  1 .
   2 .
   3 .
   4 . "NAME" COMBINED WITH "NICOMACHUS"
   5 .REVISED FROM *BASIC COMPUTER GAMES* DAVID AHL
   6 .CREATIVE COMPUTING, BY HANK CHIUPPI.
   7 :RETURN
  10 CLEAR
  20 PRINT "HELLO! I AM THE BALLY      COMPUTER.
  30 INPUT "HOW MANY LETTERS IN YOUR NAME?"L
  40 IF L<5PRINT "MY, YOU HAVE A VERY SHORT NAME!"
  50 IF L>15PRINT "WOW! YOU HAVE A VERY LONG NAME!"
  60 PRINT "BY THE WAY, WHAT IS YOUR NAME?"
  70 FOR A=1TO L;B=KP;@(A)=B
  80 NEXT A
  90 PRINT "HELLØ!";GOSUB 1000
 100 GOSUB 2000
 110 PRINT " --OOPS! SORRY";PRINT "ABOUT THAT.
 120 GOSUB 2000
 130 PRINT "HELLO!";GOSUB 3000
 140 GOSUB 2000
 150 PRINT " --THAT'S BETTER.
 160 INPUT "WOULD YOU LIKE TO PLAY A GAME? (1=YES 2=NO)"G
 170 IF G=1GOTO 200
 180 PRINT "IT WAS NICE MEETING YOU ";GOSUB 1000
 190 STOP
 200 PRINT "OK ";GOSUB 3000
 210 PRINT " --PICK A NUMBER";PRINT "BETWEEN 7 AND 100";PRINT "DON'T TELL ME W
T IT IS.
 220 GOSUB 2000
 230 INPUT "YOUR # c3 HAS A REMAINDER      OF?"Q
 240 INPUT "YOUR # c5 HAS A REMAINDER      OF?"R
 250 INPUT "YOUR # c7 HAS A REMAINDER      OF?"S
 255 D=0
 260 D=(70bQ)+(21bR)+(15bS)
 270 IF D<=105GOTO 300
 280 D=D-105
 290 GOTO 270
 300 PRINT "YOUR # IS ",D;PRINT "RIGHT?"
 310 INPUT "(1=YES 2=NO)"X
 320 IF X=1GOTO 340
 330 PRINT "I THINK YOUR ARITHMETIC      IS IN ERROR!!
 340 PRINT "WANT TO TRY AGAIN?";GOSUB 3000
 350 INPUT "(1=YES 2=NO)"Y
 360 IF Y=1GOTO 200
 370 GOTO 180
1000 FOR C=LTO 1STEP -1
1010 TV=@(C)
1020 NEXT C
1030 RETURN
2000 FOR T=1TO 2000
2010 NEXT T
2020 RETURN
3000 FOR C=1TO L;TV=@(C)
3010 NEXT C
3020 RETURN

```

Don't forget:  
 b means multiply x  
 c means divide ÷

Hank Chiuppi  
 275 St. Mary's  
 Buffalo Grove, IL  
 60090



# ARCADIAN

```
5 .YAHTZEE
6 .BY BOB WISEMAN
10 :RETURN ;CLEAR ;FC=51;BC=215;NT=1
20 GOSUB 900;B=1;T=0
30 H=13bB-9;GOSUB 700;GOSUB 300
40 GOSUB 400;GOSUB 500;B=B+1
45 FOR S=3TO 215STEP 4;MU=S;BC=S;NEXT S
50 IF B>A B=1;T=T+1
60 IF T<13GOTO 30
70 GOSUB 800;STOP
300 R=1;GOSUB 355
305 FOR D=0TO 4;GOSUB 360;NEXT D
310 R=R+1;IF R=4RETURN
315 GOSUB 355;D=0
316 IF D<0D=0
317 IF D>4D=4
318 CX=-59;CY=32-8bD;PRINT " _ ",
320 IF JX(B)MU=64;@(D)=0;BOX -71,CY,7,7,3
325 IF TR(B)D=9;GOTO 335
330 IF JY(B)=0Q=1;GOTO 320
332 IF Q=0GOTO 320
335 Q=0;CX=CX-6;PRINT " ";D=D-JY(B);IF D<8GOTO 316
340 FOR D=0TO 4;IF @(D)=0GOSUB 360
345 NEXT D;GOTO 310
355 CX=-77;CY=40;PRINT "RL#",#1,R;RETURN
360 X=-71;Y=32-Db8;Z=RND (6);@(D)=Z
365 BOX X,Y,7,7,1;MU=70+Z
370 IF Z#Zc2b2BOX X,Y,1,1,2
375 IF Z=6BOX X-2,Y,1,1,2;BOX X+2,Y,1,1,2
380 IF Z>1BOX X-2,Y+2,1,1,2;BOX X+2,Y-2,1,1,2
385 IF Z>3BOX X-2,Y-2,1,1,2;BOX X+2,Y+2,1,1,2
390 RETURN
400 C=1
405 I=C;CX=-47
410 IF C>6CX=-5;I=C-6
415 CY=40-8bI;PRINT "a",;CX=CX-6
416 IF JY(B)GOTO 416
420 IF TR(B)GOTO 450
430 I=JY(B);IF I=0GOTO 420
435 TV=32;C=C-I;IF C<1C=1
440 IF C>13C=13
445 GOTO 405
450 IF @(H+C)=-1MU=74;TV=32;RETURN
455 MU=81;MU=90;GOTO 420
500 S=0;U=650;W=645;IF C>6GOTO 525
505 FOR D=0TO 4;IF @(D)=C S=S+C
510 NEXT D;GOTO U
525 FOR D=0TO 4;S=@(D)+S;NEXT D
530 FOR D=0TO 4;FOR E=0TO 4
535 IF @(D)<@(E)F=@(D);@(D)=@(E);@(E)=F
540 NEXT E;NEXT D
545 E=1;F=1;G=1;I=1;J=1;IF C=13GOTO U
550 FOR D=1TO 4
555 IF @(D)=@(D-1)G=G+1;GOTO 568
560 GOSUB 625;IF @(D)-1=@(D-G)E=E+1;GOTO 568
565 GOSUB 640
568 NEXT D
```

*See Modifications  
2-82 and  
correction 2-88*



# ARCADIAN



```
570 IF C<11GOSUB 625;GOTO 585
575 GOSUB 640;IF F<C-7GOTO W
580 S=10bC-80;GOTO V
585 IF C<3IF I<C-4GOTO W
590 IF C=9S=25;IF I+J<5GOTO W
595 IF C=10S=50;IF I<5GOTO W
600 GOTO V
625 IF G>I J=I;I=G;GOTO 635
630 IF G>J J=G
635 G=1;RETURN
640 IF E>F F=E
642 E=1;RETURN
645 S=0
650 @(H+C)=S;GOSUB 680
665 FOR I=1TO 500;NEXT I;RETURN
680 CX=-23;I=C
685 IF C>6I=C-6;CX=17
690 CY=40-1b8;IF S<0PRINT " ";RETURN
695 PRINT #2,S,;RETURN
700 CX=-35;CY=40;PRINT "PLAYER",#2,B
702 FOR C=1TO 13
705 S=@(H+C);GOSUB 680
720 NEXT C;RETURN
800 CLEAR ;FOR B=1TO A
805 C=0;D=0;E=0;H=13bB-9
810 FOR F=1TO 13;G=@(H+F)
815 IF F<7C=C+G
820 IF F>6E=E+G
825 NEXT F;IF C>62D=35
830 PRINT "#",#1,B,#4,C," +",D," +",E," =",C+D+E
840 NEXT B;RETURN
900 INPUT "#PLAY?"A
905 CLEAR ;FOR D=0TO 13bA+4;@(D)=-1;NEXT D
910 CY=32;FOR D=1TO 6;CX=-41;PRINT #1,D,"S";NEXT D
920 CY=32;C=965;GOSUB C;PRINT "3K
930 GOSUB C;PRINT "4K
935 GOSUB C;PRINT "FH
940 GOSUB C;PRINT "YZ
945 GOSUB C;PRINT "SS
950 GOSUB C;PRINT "LS
955 GOSUB C;PRINT "CH";RETURN
965 CX=1;RETURN
```

YAHTZEE : ONE TO FOUR PLAYERS. ON YOUR TURN, USE THE JY TO POSITION THE ARROW TO THE DICE YOU WANT RE-ROLLED. THEN PUSH JX TO ERASE THE DICE (ONCE GONE THEY'RE GONE FOR GOOD). AFTER YOU HAVE 'TURNED OFF' THE DICE YOU WANT ROLLED, PULL THE TRIGGER. AFTER THREE ROLLS, YOU WILL BE SHOWN THE SCORES. USE JY TO POSITION THE ARROW TO THE ONE YOU WANT, AND THEN PULL THE TRIGGER. SCORES ALMOST LIKE REAL YAHTZEE.

BOB WISEMAN  
118 ST ANDREWS DR.  
CINCINNATI, OHIO 45245

ADS

SUPER SOFTWARE by Rob Rosenhouse. Space Games, Gambling Games, and much more. Send an SAE for descriptions and free "RND ART" program. 44 Forestbrook Dr North Plainfield, NJ 07060

CALL-TRONICS Co. of 5939 Van Nuys Blvd., Van Nuys, CA 91401 report that they are selling out all of their Bally systems, games, parts, boards, and controls, at cost and below.

ARCADE for sale, includes 2 hand controllers BASEBALL, CLOWNS, BASIC, INTERFACE Contace Lawrence Gallant 5350 Elmcrest Lane, Cincinnati, OH 45242, 513-791-2542

The Mummy's Treasure" and "Air Raid" tape, with documentation \$10. Has full memory usage, lots of action, graphics, and fascination. Check or m.o. to L&M Software, 8599 Framewood Dr. Newburgh IN 47630 (dealer inquiry invited)

Bally Arcade with CLOWNS, BRICKYARD, SEAWOLF, BASEBALL, SPACE INVADERS, PANZER, STAR BATTLE, 280ZZZAP, BASIC, INTERFACE and two hand controllers. Any reasonable offer to Mark Hunt 909 Terrace Rd., Apt 2702, Tempe, AZ 85251 602-894-0449

A GOOF last month, totally my fault, in the price of the Anderson COMPUTER EAR that we reviewed. It should be \$59.95 - it's bold as brass in their literature, don't know how I missed hitting the right number. Anyway, get their catalog, it has a couple of neat items in it, including a tic-tac-toe called tic-tac-tollah Anderson Research & Design, 1611 Lacota Lane, Burnsville, MN 55337

SALVAGE BOARDS- Well, you early birds got the cheap boards - the price has gone up to \$30, and the supply is getting low. If you are still interested in a completely stuffed (but same unknown quality) board at the above price, please send a check to cover as I have to get a quantity of requests in hand in order to get another batch. Fully repaired boards are also available at \$70. How about some innovative uses for these??? I see Microsoft is interfacing a 280 chip to the APPLE for \$350.

ARCADIAN

SOURCE TCD959  
Robert Fabris, showman  
3626 Morrie Dr.  
san Jose, CA 95127

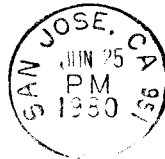

FIRST CLASS